

Octal, 16-Bit, 200ksps Differential SoftSpan ADC with Wide Input Common Mode Range

FEATURES

- 200ksps per Channel Throughput
- Eight Simultaneous Sampling Channels
- $\pm 1.25\text{LSB}$ INL (Maximum)
- Guaranteed 16-Bit, No Missing Codes
- Differential, Wide Common Mode Range Inputs
- Per-Channel SoftSpan Input Ranges:
 - ±4.096V, 0V to 4.096V, ±2.048V, 0V to 2.048V
 - ±5V, 0V to 5V, ±2.5V, 0V to 2.5V
- 91dB Single-Conversion SNR (Typical)
- -113dB THD (Typical) at $f_{IN} = 2\text{kHz}$
- 102dB CMRR (Typical) at $f_{IN} = 200\text{Hz}$
- Rail-to-Rail Input Overdrive Tolerance
- Guaranteed Operation to 125°C
- Integrated Reference and Buffer (4.096V)
- SPI CMOS (1.8V to 5V) and LVDS Serial I/O
- Internal Conversion Clock, No Cycle Latency
- 81mW Power Dissipation (Typical)
- 48-Lead (7mm x 7mm) QFN Package

APPLICATIONS

- Programmable Logic Controllers
- Industrial Process Control
- Medical Imaging
- High Speed Data Acquisition

DESCRIPTION

The LTC[®]2345-16 is a 16-bit, low noise 8-channel simultaneous sampling successive approximation register (SAR) ADC with differential, wide common mode range inputs. Operating from a 5V low voltage supply and using the internal reference and buffer, each channel of this SoftSpan™ ADC can be independently configured on a conversion-by-conversion basis to accept ± 4.096 , 0V to 4.096V, ± 2.048 V, or 0V to 2.048V signals. Individual channels may also be disabled to increase throughput on the remaining channels.

The wide input common mode range and 102dB CMRR of the LTC2345-16 analog inputs allow the ADC to directly digitize a variety of signals, simplifying signal chain design. This input signal flexibility, combined with $\pm 1.25\text{LSB}$ INL, no missing codes at 16 bits, and 91dB SNR, makes the LTC2345-16 an ideal choice for many applications requiring wide dynamic range.

The LTC2345-16 supports pin-selectable SPI CMOS (1.8V to 5V) and LVDS serial interfaces. Between one and eight lanes of data output may be employed in CMOS mode, allowing the user to optimize bus width and throughput.

LT, LT, LTC, LTM, Linear Technology and the Linear logo are registered trademarks and SoftSpan is a trademark of Linear Technology Corporation. All other trademarks are the property of their respective owners. Protected by U.S. Patents, including 7705765, 7961132, 8319673. Other Patents pending.

TYPICAL APPLICATION

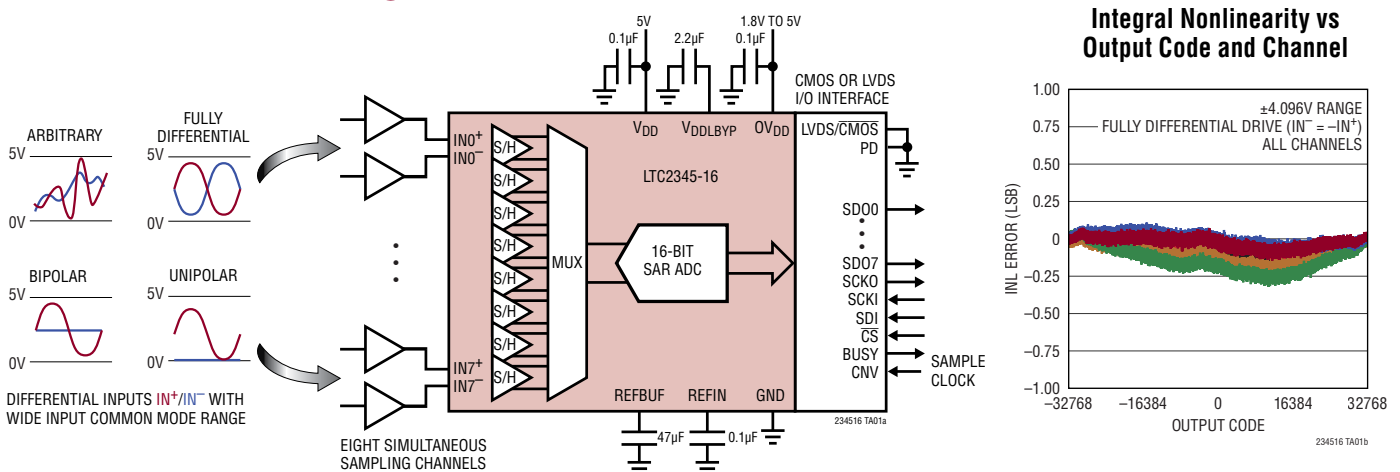

LTC2345-16

ABSOLUTE MAXIMUM RATINGS

(Notes 1, 2)

Supply Voltage (V_{DD})	6V
Supply Voltage (OV_{DD})	6V
Internal Regulated Supply Bypass (V_{DDLBY}) ... (Note 3)	
Analog Input Voltage	
$IN0^+$ to $IN7^+$,	
$IN0^-$ to $IN7^-$ (Note 4)	(-0.3V) to ($V_{DD} + 0.3V$)
REFIN	-0.3V to 2.8V
REFBUF, CNV (Note 4)	-0.3V to ($V_{DD} + 0.3V$)
Digital Input Voltage (Note 4)	-0.3V to ($OV_{DD} + 0.3V$)
Digital Output Voltage (Note 4) ..	-0.3V to ($OV_{DD} + 0.3V$)
Power Dissipation	500mW
Operating Temperature Range	
LTC2345C	0°C to 70°C
LTC2345I	-40°C to 85°C
LTC2345H	-40°C to 125°C
Storage Temperature Range	-65°C to 150°C

PIN CONFIGURATION

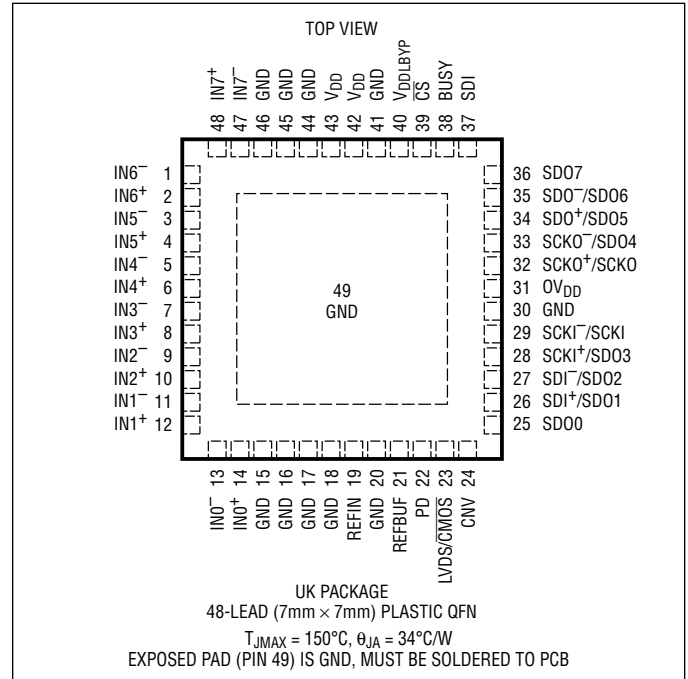

ORDER INFORMATION

(<http://www.linear.com/product/LTC2345-16#orderinfo>)

LEAD FREE FINISH	TAPE AND REEL	PART MARKING*	PACKAGE DESCRIPTION	TEMPERATURE RANGE
LTC2345CUK-16#PBF	LTC2345CUK-16#TRPBF	LTC2345UK-16	48-Lead (7mm x 7mm) Plastic QFN	0°C to 70°C
LTC2345IUK-16#PBF	LTC2345IUK-16#TRPBF	LTC2345UK-16	48-Lead (7mm x 7mm) Plastic QFN	-40°C to 85°C
LTC2345HUK-16#PBF	LTC2345HUK-16#TRPBF	LTC2345UK-16	48-Lead (7mm x 7mm) Plastic QFN	-40°C to 125°C

Consult LTC Marketing for parts specified with wider operating temperature ranges. *The temperature grade is identified by a label on the shipping container.

For more information on lead free part marking, go to: <http://www.linear.com/leadfree/>

For more information on tape and reel specifications, go to: <http://www.linear.com/tapeandreel/>. Some packages are available in 500 unit reels through designated sales channels with #TRMPBF suffix.

ELECTRICAL CHARACTERISTICS

The ● denotes the specifications which apply over the full operating temperature range, otherwise specifications are at $T_A = 25^\circ\text{C}$. (Note 5)

SYMBOL	PARAMETER	CONDITIONS		MIN	TYP	MAX	UNITS
V_{IN+}	Absolute Input Range (IN0+ to IN7+)	(Note 6)	●	0		V_{DD}	V
V_{IN-}	Absolute Input Range (IN0- to IN7-)	(Note 6)	●	0		V_{DD}	V
$V_{IN+} - V_{IN-}$	Input Differential Voltage Range	SoftSpan 7: $\pm V_{REFBUF}$ Range (Note 6) SoftSpan 6: $\pm V_{REFBUF}/1.024$ Range (Note 6) SoftSpan 5: 0V to V_{REFBUF} Range (Note 6) SoftSpan 4: 0V to $V_{REFBUF}/1.024$ Range (Note 6) SoftSpan 3: $\pm 0.5 \cdot V_{REFBUF}$ Range (Note 6) SoftSpan 2: $\pm 0.5 \cdot V_{REFBUF}/1.024$ Range (Note 6) SoftSpan 1: 0V to $0.5 \cdot V_{REFBUF}$ Range (Note 6)	● ● ● ● ● ● ●	$-V_{REFBUF}$ $-V_{REFBUF}/1.024$ 0 0 $-0.5 \cdot V_{REFBUF}$ $-0.5 \cdot V_{REFBUF}/1.024$ 0	V_{REFBUF} $V_{REFBUF}/1.024$ V_{REFBUF} $V_{REFBUF}/1.024$ $0.5 \cdot V_{REFBUF}$ $0.5 \cdot V_{REFBUF}/1.024$ $0.5 \cdot V_{REFBUF}$	V V V V V V V	
V_{CM}	Input Common Mode Voltage Range	(Note 6)	●	0		V_{DD}	V
$V_{IN+} - V_{IN-}$	Input Differential Overdrive Tolerance	(Note 7)	●	$-V_{DD}$		V_{DD}	V
I_{IN}	Analog Input Leakage Current		●	-1		1	μA
C_{IN}	Analog Input Capacitance	Sample Mode Hold Mode			50 10		pF pF
CMRR	Input Common Mode Rejection Ratio	$V_{IN+} = V_{IN-} = 3.6V_{P-P}$ 200Hz Sine	●	84	102		dB
V_{IHCNV}	CNV High Level Input Voltage		●	1.3			V
V_{ILCNV}	CNV Low Level Input Voltage		●			0.5	V
I_{INCNV}	CNV Input Current	$V_{IN} = 0V$ to V_{DD}	●	-10		10	μA

CONVERTER CHARACTERISTICS

The ● denotes the specifications which apply over the full operating temperature range, otherwise specifications are at $T_A = 25^\circ\text{C}$. (Note 8)

SYMBOL	PARAMETER	CONDITIONS		MIN	TYP	MAX	UNITS
	Resolution		●	16			Bits
	No Missing Codes		●	16			Bits
	Transition Noise	SoftSpans 7 and 6: $\pm 4.096V$ and $\pm 4V$ Ranges SoftSpans 5 and 4: 0V to 4.096V and 0V to 4V Ranges SoftSpans 3 and 2: $\pm 2.048V$ and $\pm 2V$ Ranges SoftSpan 1: 0V to 2.048V Range			0.63 1.2 1.2 2.3		LSB _{RMS} LSB _{RMS} LSB _{RMS} LSB _{RMS}
INL	Integral Linearity Error	(Note 9)	●	-1.25	± 0.50	1.25	LSB
DNL	Differential Linearity Error	(Note 10)	●	-0.9	± 0.20	0.9	LSB
ZSE	Zero-Scale Error	(Note 11)	●	-750	± 65	750	μV
	Zero-Scale Error Drift				± 2		$\mu\text{V}/^\circ\text{C}$
FSE	Full-Scale Error	(Note 11)	●	-0.13	± 0.025	0.13	%FS
	Full-Scale Error Drift				± 2.5		ppm/ $^\circ\text{C}$

DYNAMIC ACCURACY

The ● denotes the specifications which apply over the full operating temperature range, otherwise specifications are at $T_A = 25^\circ\text{C}$. $A_{IN} = -1\text{dBFS}$. (Notes 8, 12)

SYMBOL	PARAMETER	CONDITIONS	MIN	TYP	MAX	UNITS	
SINAD	Signal-to-(Noise + Distortion) Ratio	SoftSpans 7 and 6: $\pm 4.096\text{V}$ and $\pm 4\text{V}$ Ranges, $f_{IN} = 2\text{kHz}$	●	87.2	91.0		dB
		SoftSpans 5 and 4: 0V to 4.096V and 0V to 4V Ranges, $f_{IN} = 2\text{kHz}$	●	81.3	85.6		dB
		SoftSpans 3 and 2: $\pm 2.048\text{V}$ and $\pm 2\text{V}$ Ranges, $f_{IN} = 2\text{kHz}$	●	81.4	85.8		dB
		SoftSpan 1: 0V to 2.048V Range, $f_{IN} = 2\text{kHz}$	●	75.7	80.0		dB
SNR	Signal-to-Noise Ratio	SoftSpans 7 and 6: $\pm 4.096\text{V}$ and $\pm 4\text{V}$ Ranges, $f_{IN} = 2\text{kHz}$	●	87.3	91.0		dB
		SoftSpans 5 and 4: 0V to 4.096V and 0V to 4V Ranges, $f_{IN} = 2\text{kHz}$	●	81.5	85.6		dB
		SoftSpans 3 and 2: $\pm 2.048\text{V}$ and $\pm 2\text{V}$ Ranges, $f_{IN} = 2\text{kHz}$	●	81.6	85.8		dB
		SoftSpan 1: 0V to 2.048V Range, $f_{IN} = 2\text{kHz}$	●	75.8	80.0		dB
THD	Total Harmonic Distortion	SoftSpans 7 and 6: $\pm 4.096\text{V}$ and $\pm 4\text{V}$ Ranges, $f_{IN} = 2\text{kHz}$	●		-113	-99	dB
		SoftSpans 5 and 4: 0V to 4.096V and 0V to 4V Ranges, $f_{IN} = 2\text{kHz}$	●		-111	-95	dB
		SoftSpans 3 and 2: $\pm 2.048\text{V}$ and $\pm 2\text{V}$ Ranges, $f_{IN} = 2\text{kHz}$	●		-110	-96	dB
		SoftSpan 1: 0V to 2.048V Range, $f_{IN} = 2\text{kHz}$	●		-108	-95	dB
SFDR	Spurious Free Dynamic Range	SoftSpans 7 and 6: $\pm 4.096\text{V}$ and $\pm 4\text{V}$ Ranges, $f_{IN} = 2\text{kHz}$	●	99	114		dB
		SoftSpans 5 and 4: 0V to 4.096V and 0V to 4V Ranges, $f_{IN} = 2\text{kHz}$	●	95	113		dB
		SoftSpans 3 and 2: ± 2.048 and $\pm 2\text{V}$ Ranges, $f_{IN} = 2\text{kHz}$	●	96	112		dB
		SoftSpan 1: 0V to 2.048V Range, $f_{IN} = 2\text{kHz}$	●	96	109		dB
	Channel-to-Channel Crosstalk	One Channel Converting 3.6V_{P-P} 200Hz Sine in $\pm 2.048\text{V}$ Range, Crosstalk to All Other Channels			-107		dB
	-3dB Input Bandwidth			31			MHz
	Aperture Delay			1			ns
	Aperture Delay Matching			150			ps
	Aperture Jitter			3			ps _{RMS}
	Transient Response	Full-Scale Step, 0.005% Settling			200		ns

INTERNAL REFERENCE CHARACTERISTICS

The ● denotes the specifications which apply over the full operating temperature range, otherwise specifications are at $T_A = 25^\circ\text{C}$. (Note 8)

SYMBOL	PARAMETER	CONDITIONS	MIN	TYP	MAX	UNITS	
V_{REFIN}	Internal Reference Output Voltage		2.043	2.048	2.053	V	
	Internal Reference Temperature Coefficient	(Note 13)		●	5	20	ppm/ $^\circ\text{C}$
	Internal Reference Line Regulation	$V_{DD} = 4.75\text{V}$ to 5.25V			0.1		mV/V
	Internal Reference Output Impedance				20		k Ω
V_{REFIN}	REFIN Voltage Range	REFIN Overdriven (Note 6)	1.25		2.2	V	

REFERENCE BUFFER CHARACTERISTICS

The ● denotes the specifications which apply over the full operating temperature range, otherwise specifications are at $T_A = 25^\circ\text{C}$. (Note 8)

SYMBOL	PARAMETER	CONDITIONS	MIN	TYP	MAX	UNITS
V_{REFBUF}	Reference Buffer Output Voltage	REFIN Overdriven, $V_{\text{REFIN}} = 2.048\text{V}$	● 4.091	4.096	4.101	V
	REFBUF Voltage Range	REFBUF Overdriven (Notes 6, 14)	● 2.5		5	V
	REFBUF Input Impedance	$V_{\text{REFIN}} = 0\text{V}$, Buffer Disabled		13		k Ω
I_{REFBUF}	REFBUF Load Current	$V_{\text{REFBUF}} = 5\text{V}$, 8 Channels Enabled (Notes 14, 15) $V_{\text{REFBUF}} = 5\text{V}$, Acquisition Mode (Note 14)	●	1.5 0.39	1.9	mA mA

DIGITAL INPUTS AND DIGITAL OUTPUTS

The ● denotes the specifications which apply over the full operating temperature range, otherwise specifications are at $T_A = 25^\circ\text{C}$. (Note 8)

SYMBOL	PARAMETER	CONDITIONS	MIN	TYP	MAX	UNITS
CMOS Digital Inputs and Outputs						
V_{IH}	High Level Input Voltage		● $0.8 \cdot OV_{\text{DD}}$			V
V_{IL}	Low Level Input Voltage		●		$0.2 \cdot OV_{\text{DD}}$	V
I_{IN}	Digital Input Current	$V_{\text{IN}} = 0\text{V}$ to OV_{DD}	● -10		10	μA
C_{IN}	Digital Input Capacitance			5		pF
V_{OH}	High Level Output Voltage	$I_{\text{OUT}} = -500\mu\text{A}$	● $OV_{\text{DD}} - 0.2$			V
V_{OL}	Low Level Output Voltage	$I_{\text{OUT}} = 500\mu\text{A}$	●		0.2	V
I_{OZ}	Hi-Z Output Leakage Current	$V_{\text{OUT}} = 0\text{V}$ to OV_{DD}	● -10		10	μA
I_{SOURCE}	Output Source Current	$V_{\text{OUT}} = 0\text{V}$		-50		mA
I_{SINK}	Output Sink Current	$V_{\text{OUT}} = OV_{\text{DD}}$		50		mA
LVDS Digital Inputs and Outputs						
V_{ID}	Differential Input Voltage		● 200	350	600	mV
R_{ID}	On-Chip Input Termination Resistance	$\overline{\text{CS}} = 0\text{V}$, $V_{\text{ICM}} = 1.2\text{V}$ $\overline{\text{CS}} = OV_{\text{DD}}$	● 80	106 10	130	Ω M Ω
V_{ICM}	Common-Mode Input Voltage		● 0.3	1.2	2.2	V
I_{ICM}	Common-Mode Input Current	$V_{\text{IN}+} = V_{\text{IN}-} = 0\text{V}$ to OV_{DD}	● -10		10	μA
V_{OD}	Differential Output Voltage	$R_{\text{L}} = 100\Omega$ Differential Termination	● 275	350	425	mV
V_{OCM}	Common-Mode Output Voltage	$R_{\text{L}} = 100\Omega$ Differential Termination	● 1.1	1.2	1.3	V
I_{OZ}	Hi-Z Output Leakage Current	$V_{\text{OUT}} = 0\text{V}$ to OV_{DD}	● -10		10	μA

POWER REQUIREMENTS

The ● denotes the specifications which apply over the full operating temperature range, otherwise specifications are at $T_A = 25^\circ\text{C}$. (Note 8)

SYMBOL	PARAMETER	CONDITIONS	MIN	TYP	MAX	UNITS
CMOS I/O Mode						
V_{DD}	Supply Voltage		● 4.75	5.00	5.25	V
OV_{DD}	Supply Voltage		● 1.71		5.25	V
I_{VDD}	Supply Current	200ksps Sample Rate, 8 Channels Enabled	●	15.3	17.6	mA
		200ksps Sample Rate, 8 Channels Enabled, $V_{REFBUF} = 5V$ (Note 14)	●	13.7	15.8	mA
		Acquisition Mode	●	1.3	2.1	mA
		Power Down Mode (C-Grade and I-Grade)	●	65	225	μA
I_{OVDD}	Supply Current	200ksps Sample Rate, 8 Channels Enabled ($C_L = 25\text{pF}$)	●	1.8	2.6	mA
		Acquisition Mode	●	1	20	μA
P_D	Power Dissipation	200ksps Sample Rate, 8 Channels Enabled	●	81	95	mW
		Acquisition Mode	●	6.5	11	mW
		Power Down Mode (C-Grade and I-Grade)	●	0.33	1.2	mW
		Power Down Mode (H-Grade)	●	0.33	2.6	mW

LVDS I/O Mode

V_{DD}	Supply Voltage		● 4.75	5.00	5.25	V
OV_{DD}	Supply Voltage		● 2.375		5.25	V
I_{VDD}	Supply Current	200ksps Sample Rate, 8 Channels Enabled	●	17.9	20.6	mA
		200ksps Sample Rate, 8 Channels Enabled, $V_{REFBUF} = 5V$ (Note 14)	●	16.2	18.6	mA
		Acquisition Mode	●	2.8	3.8	mA
		Power Down Mode (C-Grade and I-Grade)	●	65	225	μA
I_{OVDD}	Supply Current	200ksps Sample Rate, 8 Channels Enabled ($R_L = 100\Omega$)	●	7	8.5	mA
		Acquisition or ($R_L = 100\Omega$)	●	7	8.0	mA
P_D	Power Dissipation	200ksps Sample Rate, 8 Channels Enabled	●	107	125	mW
		Acquisition Mode	●	32	39	mW
		Power Down Mode (C-Grade and I-Grade)	●	0.33	1.2	mW
		Power Down Mode (H-Grade)	●	0.33	2.6	mW

ADC TIMING CHARACTERISTICS

The ● denotes the specifications which apply over the full operating temperature range, otherwise specifications are at $T_A = 25^\circ\text{C}$. (Note 8)

SYMBOL	PARAMETER	CONDITIONS	MIN	TYP	MAX	UNITS
f_{SMPL}	Maximum Sampling Frequency	8 Channels Enabled	●		200	ksps
		7 Channels Enabled	●		225	ksps
		6 Channels Enabled	●		266	ksps
		5 Channels Enabled	●		300	ksps
		4 Channels Enabled	●		375	ksps
		3 Channels Enabled	●		450	ksps
		2 Channels Enabled	●		625	ksps
		1 Channel Enabled	●		1000	ksps
t_{CYC}	Time Between Conversions	8 Channels Enabled, $f_{SMPL} = 200\text{ksps}$	●	5000		ns
		7 Channels Enabled, $f_{SMPL} = 225\text{ksps}$	●	4444		ns
		6 Channels Enabled, $f_{SMPL} = 266\text{ksps}$	●	3750		ns
		5 Channels Enabled, $f_{SMPL} = 300\text{ksps}$	●	3333		ns
		4 Channels Enabled, $f_{SMPL} = 375\text{ksps}$	●	2666		ns
		3 Channels Enabled, $f_{SMPL} = 450\text{ksps}$	●	2222		ns
		2 Channels Enabled, $f_{SMPL} = 625\text{ksps}$	●	1600		ns
		1 Channel Enabled, $f_{SMPL} = 1000\text{ksps}$	●	1000		ns

ADC TIMING CHARACTERISTICS

The ● denotes the specifications which apply over the full operating temperature range, otherwise specifications are at $T_A = 25^\circ\text{C}$. (Note 8)

SYMBOL	PARAMETER	CONDITIONS		MIN	TYP	MAX	UNITS
t_{CONV}	Conversion Time	N Channels Enabled, $1 \leq N \leq 8$	●	$455 \cdot N - 35$	$505 \cdot N - 35$	$555 \cdot N - 35$	ns
t_{ACQ}	Acquisition Time ($t_{\text{ACQ}} = t_{\text{CYC}} - t_{\text{CONV}} - t_{\text{BUSY LH}}$)	8 Channels Enabled, $f_{\text{SMPL}} = 200\text{kpsps}$ 7 Channels Enabled, $f_{\text{SMPL}} = 225\text{kpsps}$ 6 Channels Enabled, $f_{\text{SMPL}} = 266\text{kpsps}$ 5 Channels Enabled, $f_{\text{SMPL}} = 300\text{kpsps}$ 4 Channels Enabled, $f_{\text{SMPL}} = 375\text{kpsps}$ 3 Channels Enabled, $f_{\text{SMPL}} = 450\text{kpsps}$ 2 Channels Enabled, $f_{\text{SMPL}} = 625\text{kpsps}$ 1 Channel Enabled, $f_{\text{SMPL}} = 1000\text{kpsps}$	● ● ● ● ● ● ● ●	565 564 425 563 451 562 495 450	975 924 735 823 661 722 605 510		ns ns ns ns ns ns ns ns
t_{CNVH}	CNV High Time		●	40			ns
t_{CNVL}	CNV Low Time		●	420			ns
$t_{\text{BUSY LH}}$	CNV \uparrow to BUSY Delay	$C_L = 25\text{pF}$	●			30	ns
t_{QUIET}	Digital I/O Quiet Time from CNV \uparrow		●	20			ns
t_{PDH}	PD High Time		●	40			ns
t_{PDL}	PD Low Time		●	40			ns
t_{WAKE}	REFBUF Wake-Up Time	$C_{\text{REFBUF}} = 47\mu\text{F}$, $C_{\text{REFIN}} = 0.1\mu\text{F}$			200		ms

CMOS I/O Mode

t_{SCKI}	SCKI Period	(Notes 16, 17)	●	10			ns
t_{SCKIH}	SCKI High Time		●	4			ns
t_{SCKIL}	SCKI Low Time		●	4			ns
t_{SSDISCKI}	SDI Setup Time from SCKI \uparrow	(Note 16)	●	2			ns
t_{HSDISCKI}	SDI Hold Time from SCKI \uparrow	(Note 16)	●	1			ns
t_{DSDOSCKI}	SDO Data Valid Delay from SCKI \uparrow	$C_L = 25\text{pF}$ (Note 16)	●			7.5	ns
t_{HSDOSCKI}	SDO Remains Valid Delay from SCKI \uparrow	$C_L = 25\text{pF}$ (Note 16)	●	1.5			ns
t_{SKEW}	SDO to SCKO Skew	(Note 16)	●	-1	0	1	ns
$t_{\text{DSDOBUSYL}}$	SDO Data Valid Delay from BUSY \downarrow	$C_L = 25\text{pF}$ (Note 16)	●	0			ns
t_{EN}	Bus Enable Time After $\overline{\text{CS}}\downarrow$	(Note 16)	●			15	ns
t_{DIS}	Bus Relinquish Time After $\overline{\text{CS}}\uparrow$	(Note 16)	●			15	ns

LVDS I/O Mode

t_{SCKI}	SCKI Period	(Note 18)	●	4			ns
t_{SCKIH}	SCKI High Time	(Note 18)	●	1.5			ns
t_{SCKIL}	SCKI Low Time	(Note 18)	●	1.5			ns
t_{SSDISCKI}	SDI Setup Time from SCKI	(Notes 10, 18)	●	1.2			ns
t_{HSDISCKI}	SDI Hold Time from SCKI	(Notes 10, 18)	●	-0.2			ns
t_{DSDOSCKI}	SDO Data Valid Delay from SCKI	(Notes 10, 18)	●			6	ns
t_{HSDOSCKI}	SDO Remains Valid Delay from SCKI	(Notes 10, 18)	●	1			ns
t_{SKEW}	SDO to SCKO Skew	(Note 10)	●	-0.4	0	0.4	ns
$t_{\text{DSDOBUSYL}}$	SDO Data Valid Delay from BUSY \downarrow	(Note 10)	●	0			ns
t_{EN}	Bus Enable Time After $\overline{\text{CS}}\downarrow$		●			50	ns
t_{DIS}	Bus Relinquish Time After $\overline{\text{CS}}\uparrow$		●			15	ns

ADC TIMING CHARACTERISTICS

Note 1: Stresses beyond those listed under Absolute Maximum Ratings may cause permanent damage to the device. Exposure to any Absolute Maximum Rating condition for extended periods may affect device reliability and lifetime.

Note 2: All voltage values are with respect to ground.

Note 3: V_{DDLBY} is the output of an internal voltage regulator, and should only be connected to a 2.2 μ F ceramic capacitor to bypass the pin to GND, as described in the Pin Functions section. Do not connect this pin to any external circuitry.

Note 4: When these pin voltages are taken below ground or above V_{DD} or OV_{DD} , they will be clamped by internal diodes. This product can handle currents of up to 100mA below ground or above V_{DD} or OV_{DD} without latch-up.

Note 5: $V_{DD} = 5V$ unless otherwise specified.

Note 6: Recommended operating conditions.

Note 7: Exceeding these limits on any channel may corrupt conversion results on other channels. Refer to Absolute Maximum Ratings section for pin voltage limits related to device reliability.

Note 8: $V_{DD} = 5V$, $OV_{DD} = 2.5V$, $f_{SAMPL} = 200ksps$, internal reference and buffer, fully differential input signal drive in SoftSpan ranges 7 and 6, bipolar input signal drive in SoftSpan ranges 3 and 2, unipolar input signal drive in SoftSpan ranges 5, 4 and 1, unless otherwise specified.

Note 9: Integral nonlinearity is defined as the deviation of a code from a straight line passing through the actual endpoints of the transfer curve. The deviation is measured from the center of the quantization band.

Note 10: Guaranteed by design, not subject to test.

Note 11: For bipolar SoftSpan ranges 7, 6, 3, and 2, zero-scale error is the offset voltage measured from $-0.5LSB$ when the output code flickers between 0000 0000 0000 0000 and 1111 1111 1111 1111. Full-scale error for these SoftSpan ranges is the worst-case deviation of the first and last code transitions from ideal and includes the effect of offset error. For unipolar SoftSpan ranges 5, 4, and 1, zero-scale error is the offset voltage measured from $0.5LSB$ when the output code flickers between 0000 0000 0000 0000 and 0000 0000 0000 0001. Full-scale error for these SoftSpan ranges is the worst-case deviation of the last code transition from ideal and includes the effect of offset error.

Note 12: All specifications in dB are referred to a full-scale input in the relevant SoftSpan input range, except for crosstalk, which is referred to the crosstalk injection signal amplitude.

Note 13: Temperature coefficient is calculated by dividing the maximum change in output voltage by the specified temperature range.

Note 14: When REFBUF is overdriven, the internal reference buffer must be disabled by setting $REFIN = 0V$.

Note 15: I_{REFBUF} varies proportionally with sample rate and the number of active channels.

Note 16: Parameter tested and guaranteed at $OV_{DD} = 1.71V$, $OV_{DD} = 2.5V$, and $OV_{DD} = 5.25V$.

Note 17: A t_{SCK1} period of 10ns minimum allows a shift clock frequency of up to 100MHz for rising edge capture.

Note 18: $V_{ICM} = 1.2V$, $V_{ID} = 350mV$ for LVDS differential input pairs.

CMOS Timings

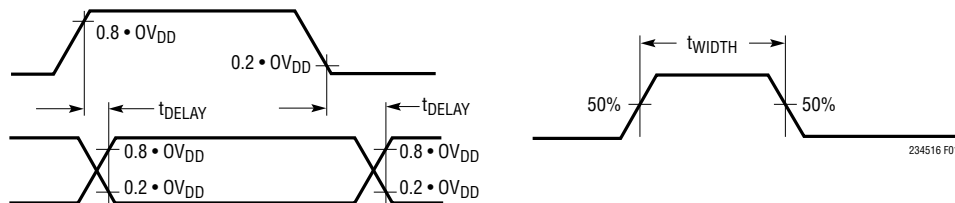

LVDS Timings (Differential)

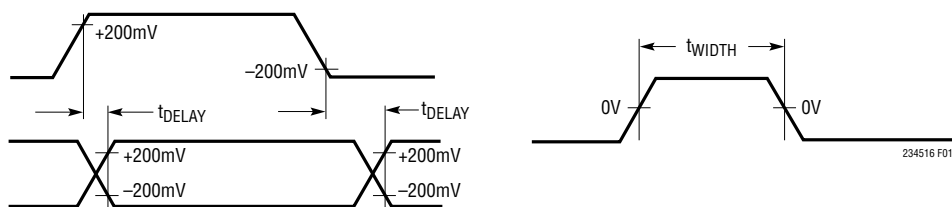
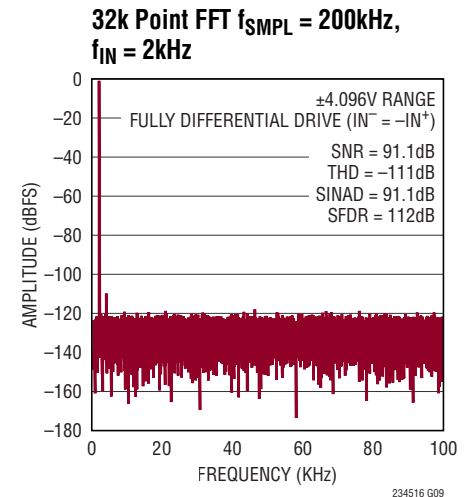
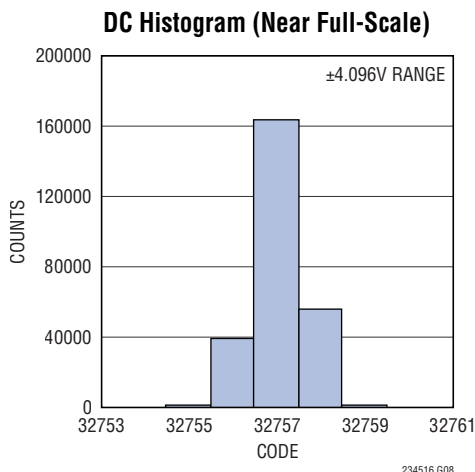
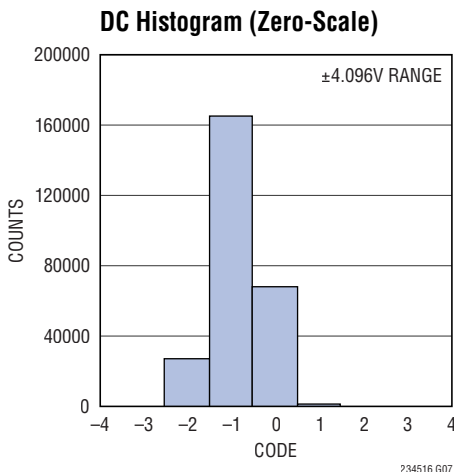
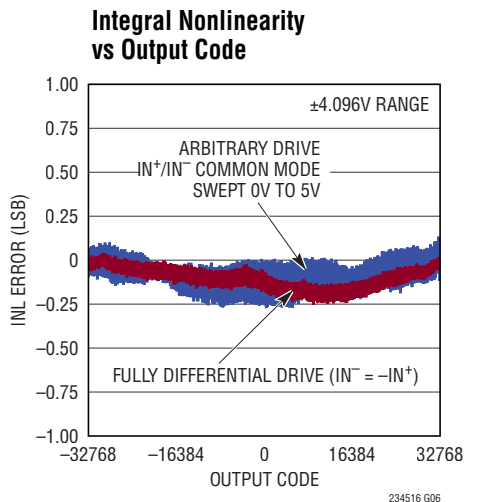
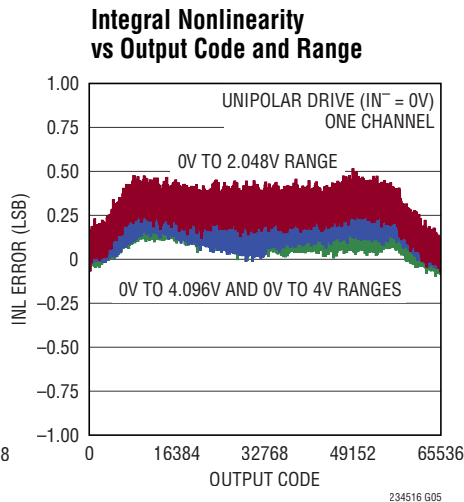
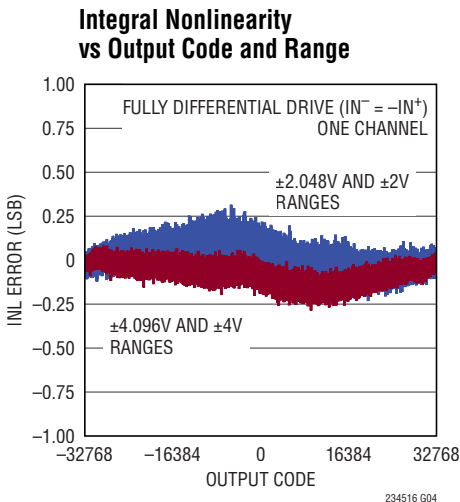
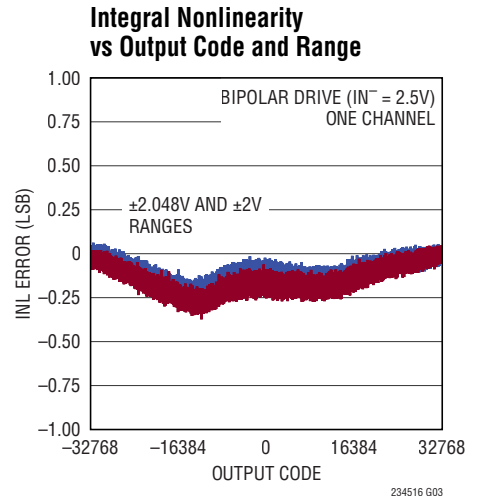
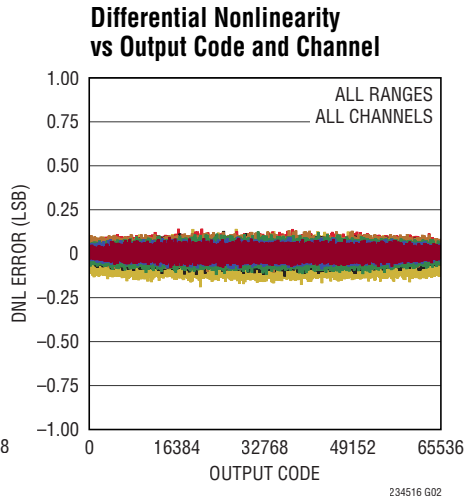
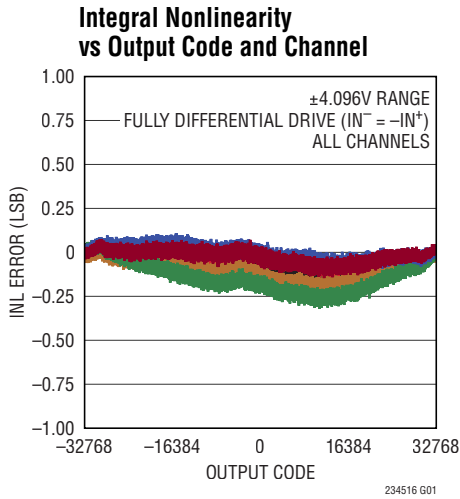

Figure 1. Voltage Levels for Timing Specifications

TYPICAL PERFORMANCE CHARACTERISTICS $T_A = 25^\circ\text{C}$, $V_{DD} = 5\text{V}$, $0V_{DD} = 2.5\text{V}$, Internal Reference and Buffer ($V_{REFBUF} = 4.096\text{V}$), $f_{SAMPL} = 200\text{ksps}$, unless otherwise noted.



TYPICAL PERFORMANCE CHARACTERISTICS $T_A = 25^\circ\text{C}$, $V_{DD} = 5\text{V}$, $0V_{DD} = 2.5\text{V}$, Internal Reference and Buffer ($V_{REFBUF} = 4.096\text{V}$), $f_{SAMPL} = 200\text{ksps}$, unless otherwise noted.

32k Point Arbitrary Two-Tone FFT
 $f_{SAMPL} = 200\text{kHz}$, $IN^+ = -7\text{dBFS}$ 2kHz Sine, $IN^- = -7\text{dBFS}$ 3.1kHz Sine

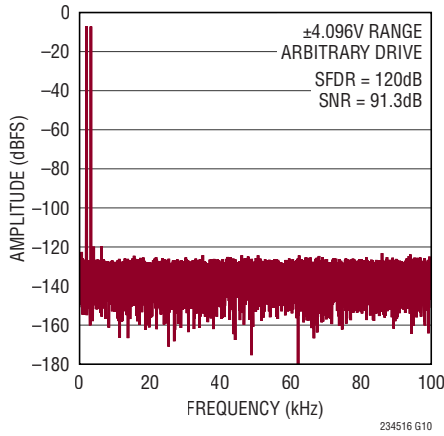

32k Point FFT $f_{SAMPL} = 200\text{kHz}$, $f_{IN} = 2\text{kHz}$

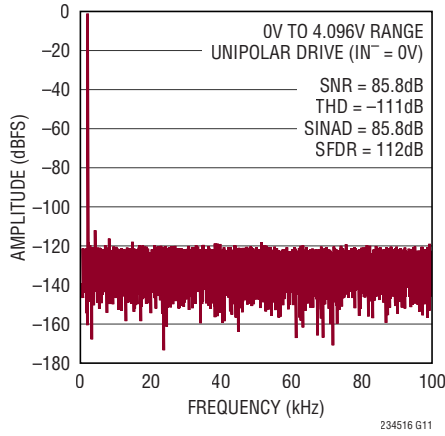

SNR, SINAD vs V_{REFBUF} , $f_{IN} = 2\text{kHz}$

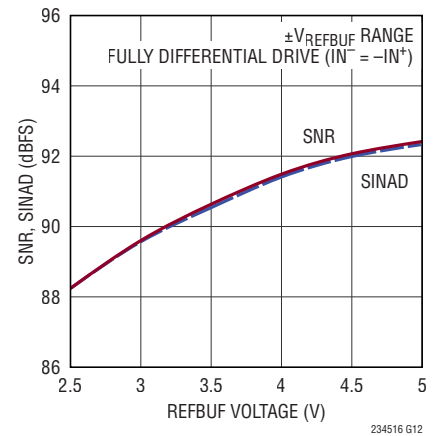

THD, Harmonics vs V_{REFBUF} , $f_{IN} = 2\text{kHz}$

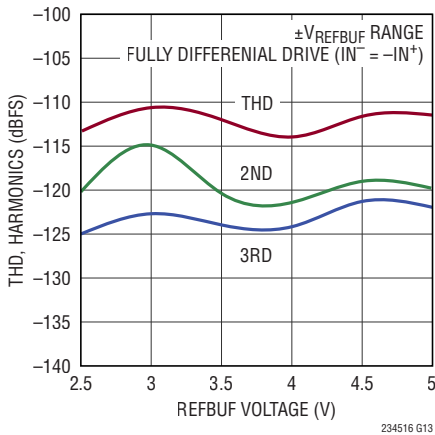

SNR, SINAD vs Input Frequency

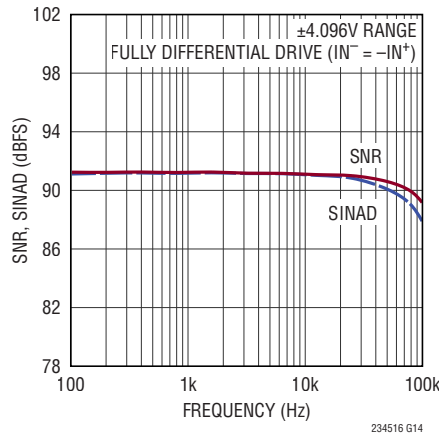

THD, Harmonics vs Input Frequency

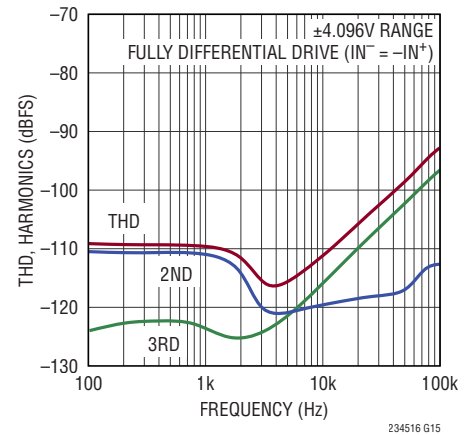

THD, Harmonics vs Input Common Mode, $f_{IN} = 2\text{kHz}$

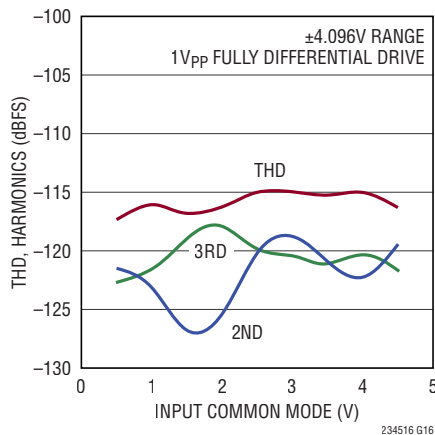

SNR, SINAD vs Input Level, $f_{IN} = 2\text{kHz}$

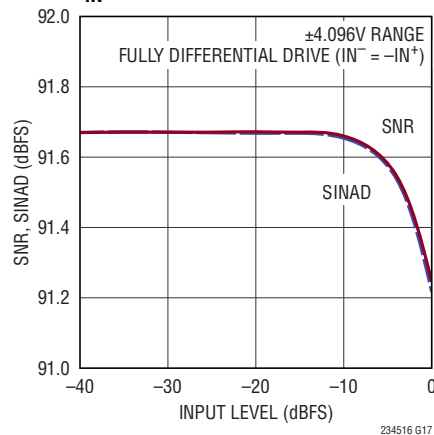

CMRR vs Input Frequency and Channel

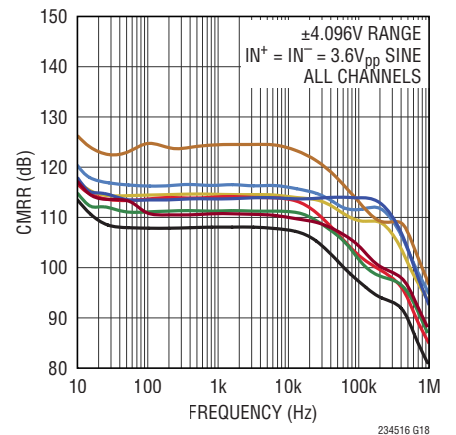

TYPICAL PERFORMANCE CHARACTERISTICS $T_A = 25^\circ\text{C}$, $V_{DD} = 5\text{V}$, $OV_{DD} = 2.5\text{V}$, Internal Reference and Buffer ($V_{REFBUF} = 4.096\text{V}$), $f_{SAMPL} = 200\text{ksps}$, unless otherwise noted.

Crosstalk vs Input Frequency and Channel

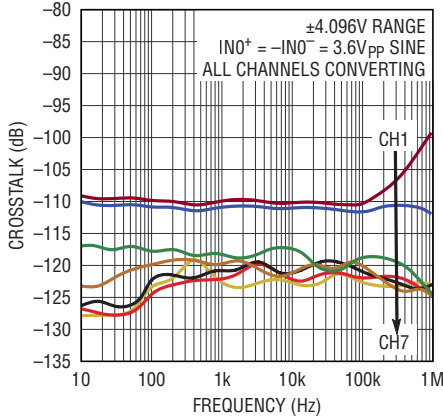

234516 G19

SNR, SINAD vs Temperature, $f_{IN} = 2\text{kHz}$

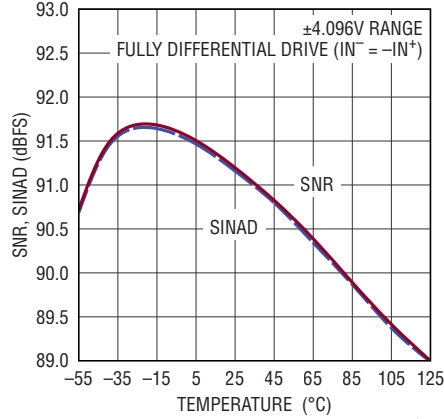

234516 G20

THD, Harmonics vs Temperature, $f_{IN} = 2\text{kHz}$

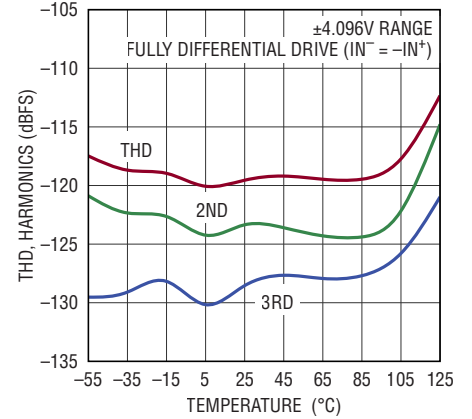

234516 G21

INL, DNL vs Temperature

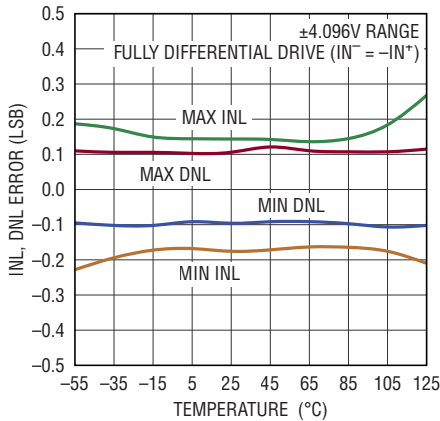

234516 G22

Positive Full-Scale Error vs Temperature and Channel

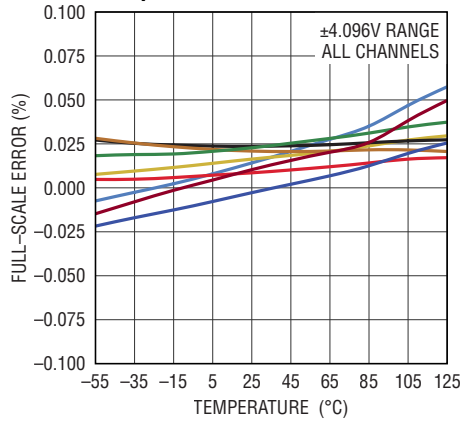

234516 G23

Negative Full-Scale Error vs Temperature and Channel

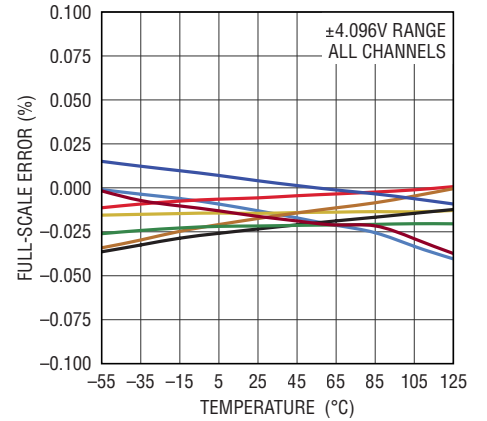

234516 G24

Zero-Scale Error vs Temperature and Channel

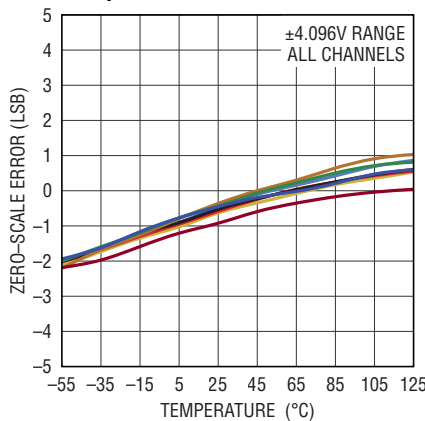

234516 G25

Supply Current vs Temperature

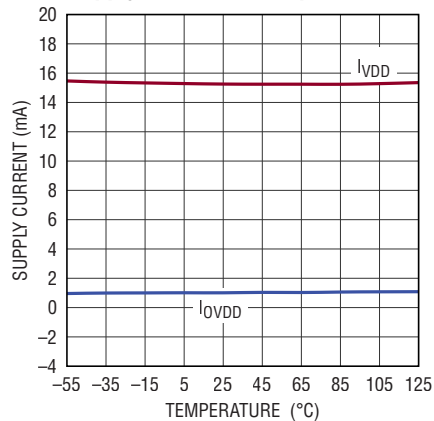

234516 G26

Power-Down Current vs Temperature

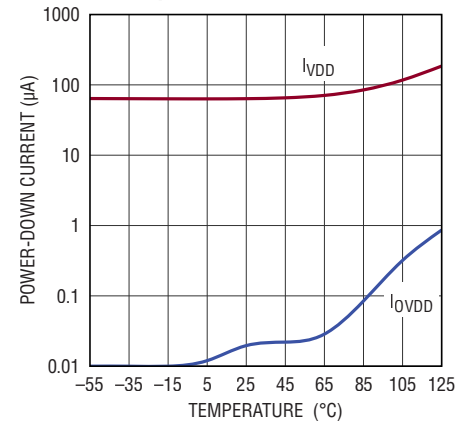

234516 G27

234516f

TYPICAL PERFORMANCE CHARACTERISTICS $T_A = 25^\circ\text{C}$, $V_{DD} = 5\text{V}$, $OV_{DD} = 2.5\text{V}$, Internal Reference and Buffer ($V_{REFBUF} = 4.096\text{V}$), $f_{SAMPL} = 200\text{ksps}$, unless otherwise noted.

Offset Error vs Input Common Mode and Channel

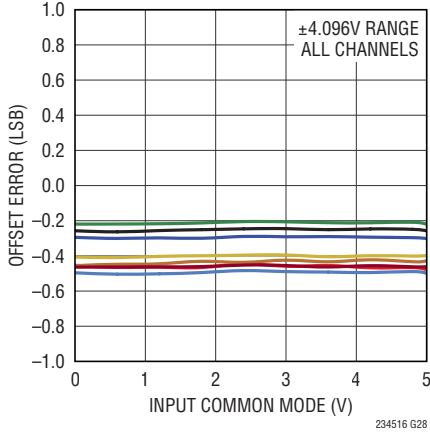

Internal Reference Output vs Temperature

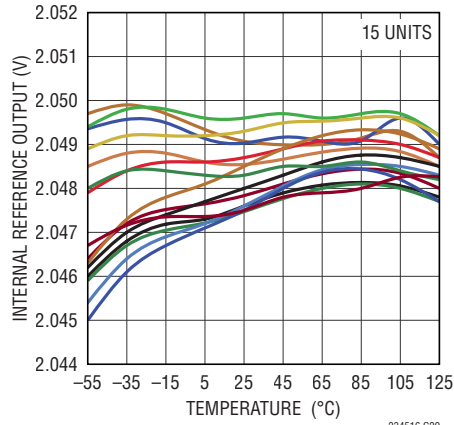

PSRR vs Frequency

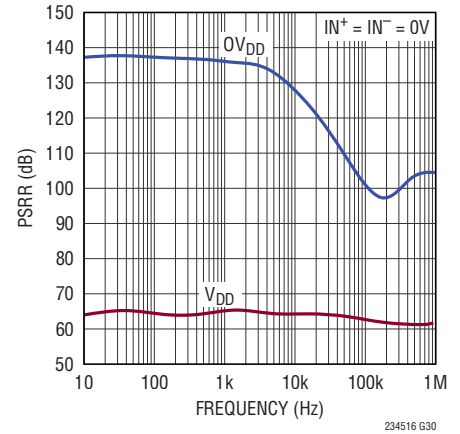

Supply Current vs Sampling Rate

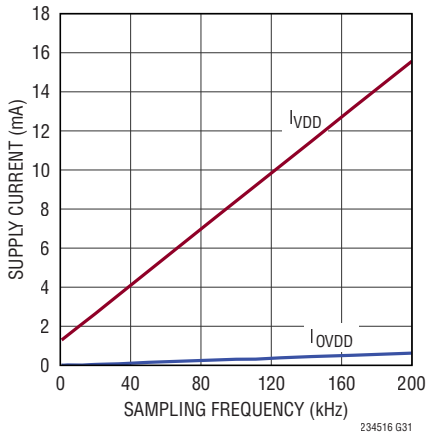

Power Dissipation vs Sampling Rate, N Channels Enabled

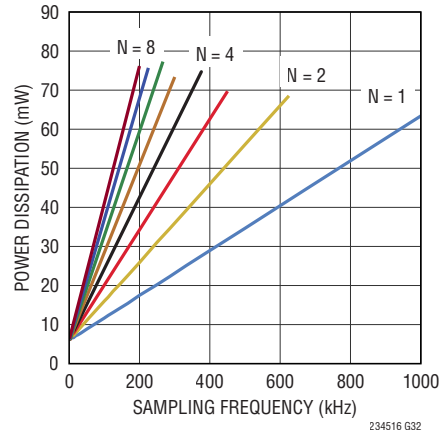

Step Response (Large-Signal Settling)

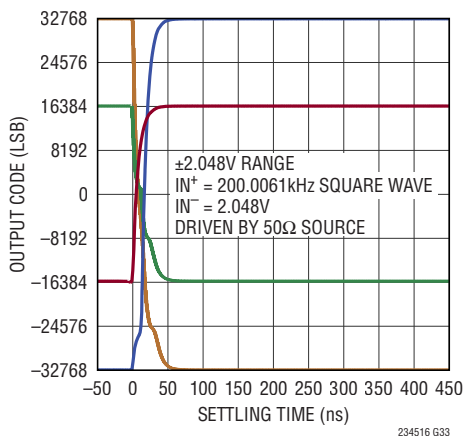

Step Response (Fine Settling)

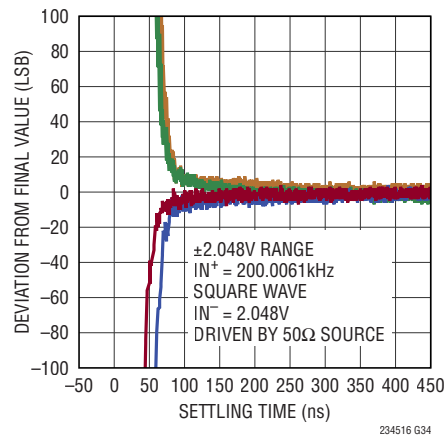

PIN FUNCTIONS

Pins that are the Same for All Digital I/O Modes

IN0⁺ to IN7⁺, IN0⁻ to IN7⁻ (Pins 1, 2, 3, 4, 5, 6, 7, 8, 9, 10, 11, 12, 13, 14, 47, and 48): Positive and Negative Analog Inputs, Channels 0 to 7. The converter simultaneously samples and digitizes ($V_{IN+} - V_{IN-}$) for all channels. Wide input common mode range ($0V \leq V_{CM} \leq V_{DD}$) and high common mode rejection allow the inputs to accept a wide variety of signal swings. Full-scale input range is determined by the channel's SoftSpan configuration.

GND (Pins 15, 16, 17, 18, 20, 30, 41, 44, 45, 46, 49): Ground. Solder all GND pins to a solid ground plane.

REFIN (Pin 19): Bandgap Reference Output/Reference Buffer Input. An internal bandgap reference nominally outputs 2.048V on this pin. An internal reference buffer amplifies V_{REFIN} to create the converter master reference voltage $V_{REFBUF} = 2 \cdot V_{REFIN}$ on the REFBUF pin. When using the internal reference, bypass REFIN to GND (Pin 20) close to the pin with a 0.1 μ F ceramic capacitor to filter the bandgap output noise. If more accuracy is desired, overdrive REFIN with an external reference in the range of 1.25V to 2.2V.

REFBUF (Pin 21): Internal Reference Buffer Output. An internal reference buffer amplifies V_{REFIN} to create the converter master reference voltage $V_{REFBUF} = 2 \cdot V_{REFIN}$ on this pin, nominally 4.096V when using the internal bandgap reference. Bypass REFBUF to GND (Pin 20) close to the pin with a 47 μ F ceramic capacitor. The internal reference buffer may be disabled by grounding its input at REFIN. With the buffer disabled, overdrive REFBUF with an external reference voltage in the range of 2.5V to 5V. When using the internal reference buffer, limit the loading of any external circuitry connected to REFBUF to less than 10 μ A. Using a high input impedance amplifier to buffer V_{REFBUF} to any external circuits is recommended.

PD (Pin 22): Power Down Input. When this pin is brought high, the LTC2345-16 is powered down and subsequent conversion requests are ignored. If this occurs during a conversion, the device powers down once the conversion completes. If this pin is brought high twice without an intervening conversion, an internal global reset is initiated, equivalent to a power-on-reset event. Logic levels are determined by OV_{DD} .

LVDS/ $\overline{\text{CMOS}}$ (Pin 23): I/O Mode Select. Tie this pin to OV_{DD} to select LVDS I/O mode, or to ground to select CMOS I/O mode. Logic levels are determined by OV_{DD} .

CNV (Pin 24): Conversion Start Input. A rising edge on this pin puts the internal sample-and-holds into the hold mode and initiates a new conversion. CNV is not gated by $\overline{\text{CS}}$, allowing conversions to be initiated independent of the state of the serial I/O bus.

BUSY (Pin 38): Busy Output. The BUSY signal indicates that a conversion is in progress. This pin transitions low-to-high at the start of each conversion and stays high until the conversion is complete. Logic levels are determined by OV_{DD} .

V_{DDLBYP} (Pin 40): Internal 2.5V Regulator Bypass Pin. The voltage on this pin is generated via an internal regulator operating off of V_{DD} . This pin must be bypassed to GND close to the pin with a 2.2 μ F ceramic capacitor. Do not connect this pin to any external circuitry.

V_{DD} (Pins 42, 43): 5V Power Supply. The range of V_{DD} is 4.75V to 5.25V. Connect Pins 42 and 43 together and bypass the V_{DD} network to GND with a shared 0.1 μ F ceramic capacitor close to the pins.

PIN FUNCTIONS

CMOS I/O Mode

SD00 to SD07 (Pins 25, 26, 27, 28, 33, 34, 35, and 36): CMOS Serial Data Outputs, Channels 0 to 7. The most recent conversion result along with channel configuration information is clocked out onto the SDO pins on each rising edge of SCKI. Output data formatting is described in the Digital Interface section. Leave unused SDO outputs unconnected. Logic levels are determined by OV_{DD} .

SCKI (Pin 29): CMOS Serial Clock Input. Drive SCKI with the serial I/O clock. SCKI rising edges latch serial data in on SDI and clock serial data out on SD00 to SD07. For standard SPI bus operation, capture output data at the receiver on rising edges of SCKI. SCKI is allowed to idle either high or low. Logic levels are determined by OV_{DD} .

OV_{DD} (Pin 31): I/O Interface Power Supply. In CMOS I/O mode, the range of OV_{DD} is 1.71V to 5.25V. Bypass OV_{DD} to GND (Pin 30) close to the pin with a 0.1 μ F ceramic capacitor.

SCKO (Pin 32): CMOS Serial Clock Output. SCKI rising edges trigger transitions on SCKO that are skew-matched to the serial output data streams on SD00 to SD07. The resulting SCKO frequency is half that of SCKI. Rising and falling edges of SCKO may be used to capture SDO data at the receiver (FPGA) in double data rate (DDR) fashion. For standard SPI bus operation, SCKO is not used and should be left unconnected. SCKO is forced low at the falling edge of BUSY. Logic levels are determined by OV_{DD} .

SDI (Pin 37): CMOS Serial Data Input. Drive this pin with the desired 24-bit SoftSpan configuration word (see Table 1a), latched on the rising edges of SCKI. If all channels will be configured to operate only in SoftSpan 7, tie SDI to OV_{DD} . Logic levels are determined by OV_{DD} .

\overline{CS} (Pin 39): Chip Select Input. The serial data I/O bus is enabled when \overline{CS} is low and is disabled and Hi-Z when \overline{CS} is high. \overline{CS} also gates the external shift clock, SCKI. Logic levels are determined by OV_{DD} .

LVDS I/O Mode

SD00, SD07, SDI (Pins 25, 36 and 37): CMOS Serial Data I/O. In LVDS I/O mode, these pins are Hi-Z.

SDI⁺, SDI⁻ (Pins 26 and 27): LVDS Positive and Negative Serial Data Input. Differentially drive SDI⁺/SDI⁻ with the desired 24-bit SoftSpan configuration word (see Table 1a), latched on both the rising and falling edges of SCKI⁺/SCKI⁻. The SDI⁺/SDI⁻ input pair is internally terminated with a 100 Ω differential resistor when $\overline{CS} = 0$.

SCKI⁺, SCKI⁻ (Pins 28 and 29): LVDS Positive and Negative Serial Clock Input. Differentially drive SCKI⁺/SCKI⁻ with the serial I/O clock. SCKI⁺/SCKI⁻ rising and falling edges latch serial data in on SDI⁺/SDI⁻ and clock serial data out on SDO⁺/SDO⁻. Idle SCKI⁺/SCKI⁻ low, including when transitioning \overline{CS} . The SCKI⁺/SCKI⁻ input pair is internally terminated with a 100 Ω differential resistor when $\overline{CS} = 0$.

OV_{DD} (Pin 31): I/O Interface Power Supply. In LVDS I/O mode, the range of OV_{DD} is 2.375V to 5.25V. Bypass OV_{DD} to GND (Pin 30) close to the pin with a 0.1 μ F ceramic capacitor.

SCKO⁺, SCKO⁻ (Pins 32 and 33): LVDS Positive and Negative Serial Clock Output. SCKO⁺/SCKO⁻ outputs a copy of the input serial I/O clock received on SCKI⁺/SCKI⁻, skew-matched with the serial output data stream on SDO⁺/SDO⁻. Use the rising and falling edges of SCKO⁺/SCKO⁻ to capture SDO⁺/SDO⁻ data at the receiver (FPGA). The SCKO⁺/SCKO⁻ output pair must be differentially terminated with a 100 Ω resistor at the receiver (FPGA).

SDO⁺, SDO⁻ (Pins 34 and 35): LVDS Positive and Negative Serial Data Output. The most recent conversion result along with channel configuration information is clocked out onto SDO⁺/SDO⁻ on both rising and falling edges of SCKI⁺/SCKI⁻, beginning with channel 0. The SDO⁺/SDO⁻ output pair must be differentially terminated with a 100 Ω resistor at the receiver (FPGA).

\overline{CS} (Pin 39): Chip Select Input. The serial data I/O bus is enabled when \overline{CS} is low, and is disabled and Hi-Z when \overline{CS} is high. \overline{CS} also gates the external shift clock, SCKI⁺/SCKI⁻. The internal 100 Ω differential termination resistors on the SCKI⁺/SCKI⁻ and SDI⁺/SDI⁻ input pairs are disabled when \overline{CS} is high. Logic levels are determined by OV_{DD} .

CONFIGURATION TABLES

Table 1a. SoftSpan Configuration Table. Use This Table with Table 1b to Choose Independent Binary SoftSpan Codes SS[2:0] for Each Channel Based on Desired Analog Input Range. Combine SoftSpan Codes to Form 24-Bit SoftSpan Configuration Word S[23:0]. Use Serial Interface to Write SoftSpan Configuration Word to LTC2345-16, as shown in Figure 19

BINARY SoftSpan CODE SS[2:0]	ANALOG INPUT RANGE	FULL SCALE RANGE	BINARY FORMAT OF CONVERSION RESULT
111	$\pm V_{REFBUF}$	$2 \cdot V_{REFBUF}$	Two's Complement
110	$\pm V_{REFBUF}/1.024$	$2 \cdot V_{REFBUF}/1.024$	Two's Complement
101	0V to V_{REFBUF}	V_{REFBUF}	Straight Binary
100	0V to $V_{REFBUF}/1.024$	$V_{REFBUF}/1.024$	Straight Binary
011	$\pm 0.5 \cdot V_{REFBUF}$	V_{REFBUF}	Two's Complement
010	$\pm 0.5 \cdot V_{REFBUF}/1.024$	$V_{REFBUF}/1.024$	Two's Complement
001	0V to $0.5 \cdot V_{REFBUF}$	$0.5 \cdot V_{REFBUF}$	Straight Binary
000	Channel Disabled	Channel Disabled	All Zeros

Table 1b. Reference Configuration Table. The LTC2345-16 Supports Three Reference Configurations. Analog Input Range Scales with the Converter Master Reference Voltage, V_{REFBUF}

REFERENCE CONFIGURATION	V_{REFIN}	V_{REFBUF}	BINARY SoftSpan CODE SS[2:0]	ANALOG INPUT RANGE
Internal Reference with Internal Buffer	2.048V	4.096V	111	$\pm 4.096V$
			110	$\pm 4V$
			101	0V to 4.096V
			100	0V to 4V
			011	$\pm 2.048V$
			010	$\pm 2V$
			001	0V to 2.048V
External Reference with Internal Buffer (REFIN Pin Externally Overdriven)	1.25V (Min Value)	2.5V	111	$\pm 2.5V$
			110	$\pm 2.441V$
			101	0V to 2.5V
			100	0V to 2.441V
			011	$\pm 1.25V$
			010	$\pm 1.221V$
			001	0V to 1.25V
	2.2V (Max Value)	4.4V	111	$\pm 4.4V$
			110	$\pm 4.297V$
			101	0V to 4.4V
			100	0V to 4.297V
			011	$\pm 2.2V$
			010	$\pm 2.148V$
			001	0V to 2.2V

CONFIGURATION TABLES

Table 1b. Reference Configuration Table (Continued). The LTC2345-16 Supports Three Reference Configurations. Analog Input Range Scales with the Converter Master Reference Voltage, V_{REFBUF}

REFERENCE CONFIGURATION	V_{REFIN}	V_{REFBUF}	BINARY SoftSpan CODE SS[2:0]	ANALOG INPUT RANGE
External Reference Unbuffered (REFBUF Pin Externally Overdriven, REFIN Pin Grounded)	0V	2.5V (Min Value)	111	$\pm 2.5V$
			110	$\pm 2.441V$
			101	0V to 2.5V
			100	0V to 2.441V
			011	$\pm 1.25V$
			010	$\pm 1.221V$
			001	0V to 1.25V
	0V	5V (Max Value)	111	$\pm 5V$
			110	$\pm 4.883V$
			101	0V to 5V
			100	0V to 4.883V
			011	$\pm 2.5V$
			010	$\pm 2.441V$
			001	0V to 2.5V

FUNCTIONAL BLOCK DIAGRAM

CMOS I/O Mode

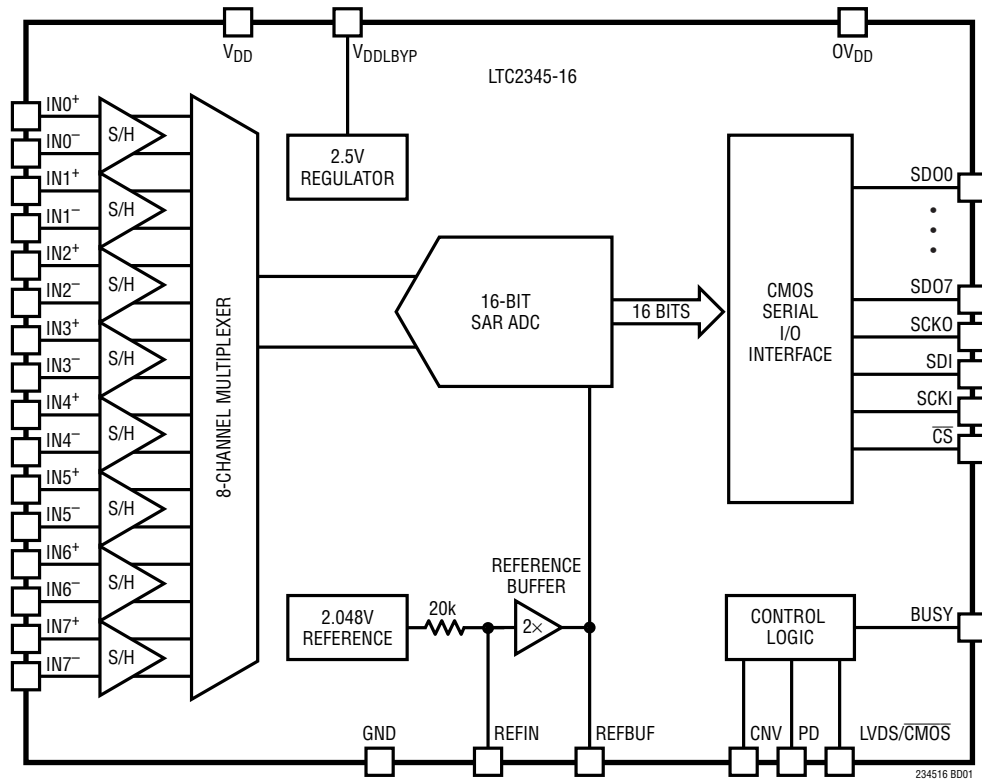

234516 BD01

FUNCTIONAL BLOCK DIAGRAM

LVDS I/O Mode

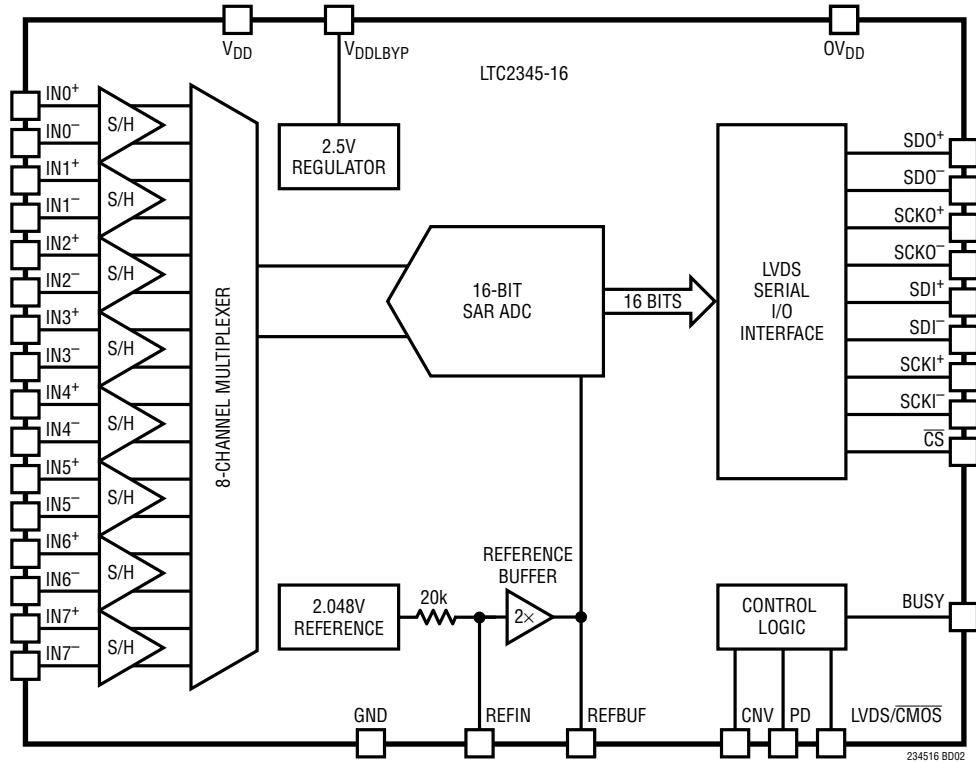

234516 BD02

TIMING DIAGRAM

CMOS I/O Mode

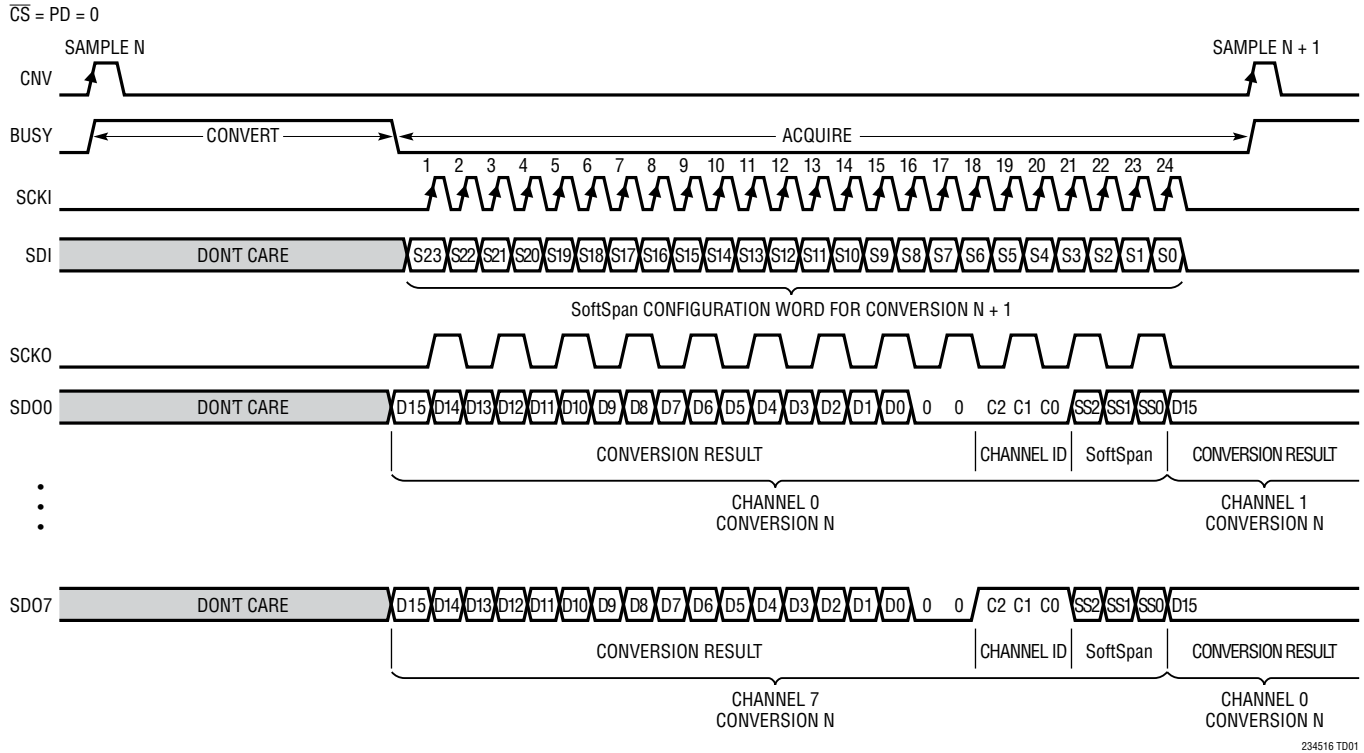

LVDS I/O Mode

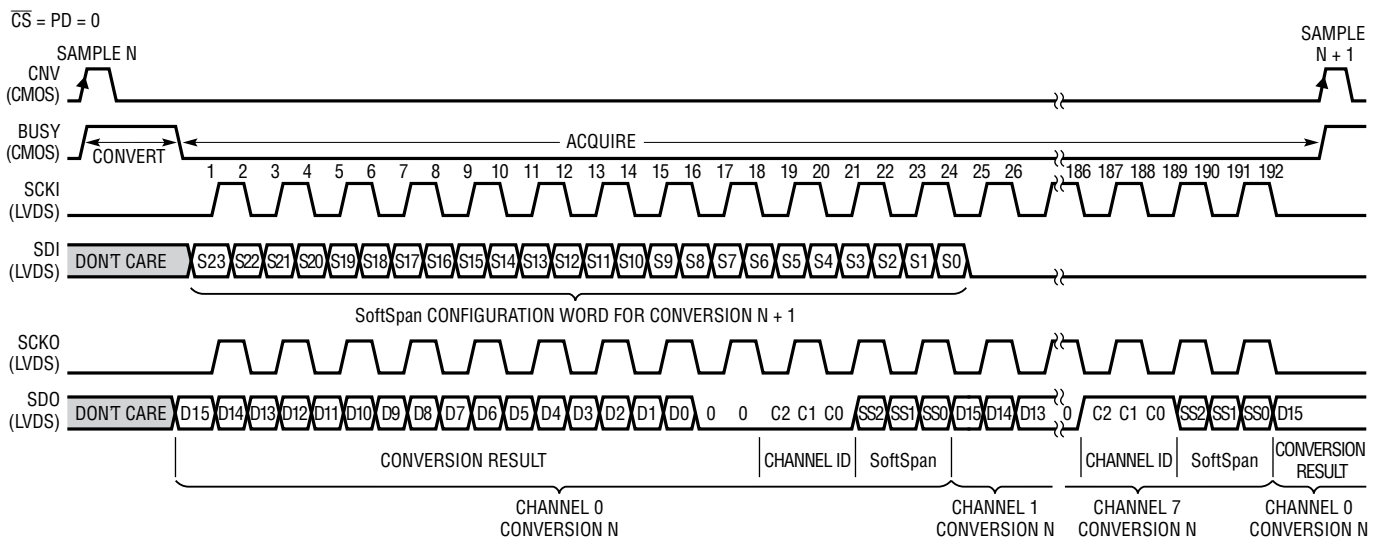

APPLICATIONS INFORMATION

OVERVIEW

The LTC2345-16 is a 16-bit, low noise 8-channel simultaneous sampling successive approximation register (SAR) ADC with differential, wide common mode range inputs. Using the integrated low-drift reference and buffer ($V_{REFBUF} = 4.096V$ nominal), each channel of this SoftSpan ADC can be independently configured on a conversion-by-conversion basis to accept $\pm 4.096V$, $0V$ to $4.096V$, $\pm 2.048V$, or $0V$ to $2.048V$ signals. The input signal range may be expanded up to $\pm 5V$ using an external $5V$ reference. Individual channels may also be disabled to increase throughput on the remaining channels.

The wide input common mode range and high CMRR ($102dB$ typical, $V_{IN+} = V_{IN-} = 3.6V_{P-P}$ $200Hz$ Sine) of the LTC2345-16 analog inputs allow the ADC to directly digitize a variety of signals, simplifying signal chain design. This input signal flexibility, combined with $\pm 1.25LSB$ INL, no missing codes at 16-bits, and $91dB$ SNR, makes the LTC2345-16 an ideal choice for many applications requiring wide dynamic range.

The LTC2345-16 supports pin-selectable SPI CMOS ($1.8V$ to $5V$) and LVDS serial interfaces, enabling it to communicate equally well with legacy microcontrollers and modern FPGAs. In CMOS mode, applications may employ between one and eight lanes of serial output data, allowing the user to optimize bus width and data throughput. The LTC2345-16 typically dissipates $81mW$ when converting eight analog input channels simultaneously at $200ksps$ per channel throughput. An optional power-down mode may be employed to further reduce power consumption during inactive periods.

CONVERTER OPERATION

The LTC2345-16 operates in two phases. During the acquisition phase, the sampling capacitors in each channel's sample-and-hold (S/H) circuit connect to their respective analog input pins and track the differential analog input voltage ($V_{IN+} - V_{IN-}$). A rising edge on the CNV pin transi-

tions all channels' S/H circuits from track mode to hold mode, simultaneously sampling the input signals on all channels and initiating a conversion. During the conversion phase, each channel's sampling capacitors are connected, one channel at a time, to a 16-bit charge redistribution capacitor D/A converter (CDAC). The CDAC is sequenced through a successive approximation algorithm, effectively comparing the sampled input voltage with binary-weighted fractions of the channel's SoftSpan full-scale range (e.g., $V_{FSR}/2$, $V_{FSR}/4$... $V_{FSR}/65536$) using a differential comparator. At the end of this process, the CDAC output approximates the channel's sampled analog input. Once all channels have been converted in this manner, the ADC control logic prepares the 16-bit digital output codes from each channel for serial transfer.

TRANSFER FUNCTION

The LTC2345-16 digitizes each channel's full-scale voltage range into 2^{16} levels. In conjunction with the ADC master reference voltage, V_{REFBUF} , a channel's SoftSpan configuration determines its input voltage range, full-scale range, LSB size, and the binary format of its conversion result, as shown in Tables 1a and 1b. For example, employing the internal reference and buffer ($V_{REFBUF} = 4.096V$ nominal), SoftSpan 7 configures a channel to accept a $\pm 4.096V$ bipolar analog input voltage range, which corresponds to a $8.192V$ full-scale range with a $125\mu V$ LSB. Other SoftSpan configurations and reference voltages may be employed to convert both larger and smaller bipolar and unipolar input ranges. Conversion results are output in two's complement binary format for all bipolar SoftSpan ranges, and in straight binary format for all unipolar SoftSpan ranges. The ideal two's complement transfer function is shown in Figure 2, while the ideal straight binary transfer function is shown in Figure 3.

APPLICATIONS INFORMATION

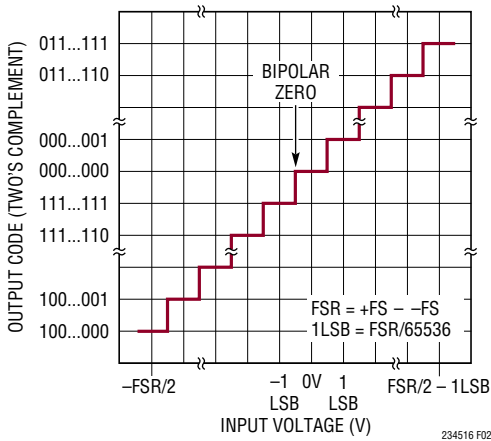

Figure 2. LTC2345-16 Two's Complement Transfer Function

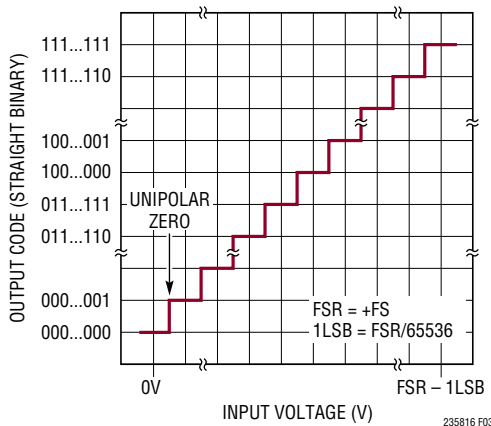

Figure 3. LTC2345-16 Straight Binary Transfer Function

ANALOG INPUTS

Each channel of the LTC2345-16 simultaneously samples the voltage difference ($V_{IN+} - V_{IN-}$) between its analog input pins over a wide common mode input range while attenuating unwanted signals common to both input pins by the common-mode rejection ratio (CMRR) of the ADC. Wide common mode input range coupled with

high CMRR allows the IN^+/IN^- analog inputs to swing with an arbitrary relationship to each other, provided each pin remains between ground and V_{DD} . This unique feature of the LTC2345-16 enables it to accept a wide variety of signal swings, including traditional classes of analog input signals such as pseudo-differential unipolar, pseudo-differential bipolar, and fully differential, simplifying signal chain design.

In all SoftSpan ranges, each channel's analog inputs can be modeled by the equivalent circuit shown in Figure 4. At the start of acquisition, the 40pF sampling capacitors (C_{IN}) connect to the analog input pins IN^+/IN^- through the sampling switches, each of which has approximately 130 Ω (R_{IN}) of on-resistance. The initial voltage on both sampling capacitors at the start of acquisition is approximately equal to the sampled common-mode voltage ($(V_{IN+} + V_{IN-})/2$) from the prior conversion. The external circuitry connected to IN^+ and IN^- must source or sink the charge that flows through R_{IN} as the sampling capacitors settle from their initial voltages to the new input pin voltages over the course of the acquisition interval. During conversion and power down modes, the analog inputs draw only a small leakage current. The diodes at the inputs provide ESD protection.

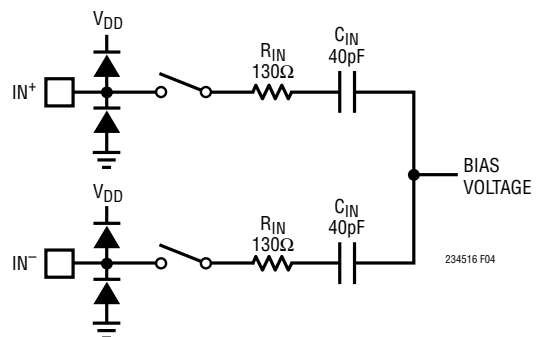

Figure 4. Equivalent Circuit for Differential Analog Inputs, Single Channel Shown

APPLICATIONS INFORMATION

Bipolar SoftSpan Input Ranges

For channels configured in SoftSpan ranges 7, 6, 3, or 2, the LTC2345-16 digitizes the differential analog input voltage ($V_{IN+} - V_{IN-}$) over a bipolar span of $\pm V_{REFBUF}$, $\pm V_{REFBUF}/1.024$, $\pm 0.5 \cdot V_{REFBUF}$, or $\pm 0.5 \cdot V_{REFBUF}/1.024$, respectively, as shown in Table 1a. These SoftSpan ranges are useful for digitizing input signals where IN^+ and IN^- swing above and below each other. Traditional examples include fully differential input signals, where IN^+ and IN^- are driven 180 degrees out-of-phase with respect to each other centered around a common mode voltage $(V_{IN+} + V_{IN-})/2$, and pseudo-differential bipolar input signals, where IN^+ swings above and below a reference level, driven on IN^- . Regardless of the chosen SoftSpan range, the wide common mode input range and high CMRR of the IN^+/IN^- analog inputs allow them to swing with an arbitrary relationship to each other, provided each pin remains between ground and V_{DD} . The output data format for all bipolar SoftSpan ranges is two's complement.

Unipolar SoftSpan Input Ranges

For channels configured in SoftSpan ranges 5, 4, or 1, the LTC2345-16 digitizes the differential analog input voltage ($V_{IN+} - V_{IN-}$) over a unipolar span of 0V to V_{REFBUF} , 0V to $V_{REFBUF}/1.024$, or 0V to $0.5 \cdot V_{REFBUF}$, respectively, as shown in Table 1a. These SoftSpan ranges are useful for digitizing input signals where IN^+ remains above IN^- . A traditional example includes pseudo-differential unipolar input signals, where IN^+ swings above a ground reference level, driven on IN^- . Regardless of the chosen SoftSpan range, the wide common mode range and high CMRR of the IN^+/IN^- analog inputs allow them to swing with an arbitrary relationship to each other, provided each pin remains between ground and V_{DD} . The output data format for all unipolar SoftSpan ranges is straight binary.

INPUT DRIVE CIRCUITS

The initial voltage on each channel's sampling capacitors at the start of acquisition must settle to the new input pin voltages during the acquisition interval. The external circuitry connected to IN^+ and IN^- must source or sink the charge that flows through R_{IN} as this settling occurs.

The LTC2345-16 sampling network RC time constant of 5.2ns implies a 16-bit settling time to a full-scale step of approximately $11 \cdot (R_{IN} \cdot C_{IN}) = 57$ ns. The impedance and self-settling of external circuitry connected to the analog input pins will increase the overall settling time required. Low impedance sources can directly drive the inputs of the LTC2345-16 without gain error, but high impedance sources should be buffered to ensure sufficient settling during acquisition and to optimize the linearity and distortion performance of the ADC. Settling time is an important consideration even for DC input signals, as the voltages on the sampling capacitors will differ from the analog input pin voltages at the start of acquisition.

Most applications should use a buffer amplifier to drive the analog inputs of the LTC2345-16. The amplifier provides low output impedance, enabling fast settling of the analog signal during the acquisition phase. It also provides isolation between the signal source and the charge flow at the analog inputs when entering acquisition.

Input Filtering

The noise and distortion of an input buffer amplifier and other supporting circuitry must be considered since they add to the ADC noise and distortion. Noisy input signals should be filtered prior to the buffer amplifier with a low-bandwidth filter to minimize noise. The simple one-pole RC lowpass filter shown in Figure 5 is sufficient for many applications.

At the output of the buffer, a lowpass RC filter network formed by the 130Ω sampling switch on-resistance (R_{IN}) and the 40pF sampling capacitance (C_{IN}) limits the input bandwidth on each channel to 31MHz, which is fast enough to allow for sufficient transient settling during acquisition while simultaneously filtering driver wideband noise. A buffer amplifier with low noise density should be selected to minimize SNR degradation over this bandwidth. An additional filter network may be placed between the buffer output and ADC input to further minimize the noise contribution of the buffer and reduce disturbances to the buffer from ADC acquisition transients. A simple one-pole lowpass RC filter is sufficient for many applications. It is important that the RC time constant of this filter be small

APPLICATIONS INFORMATION

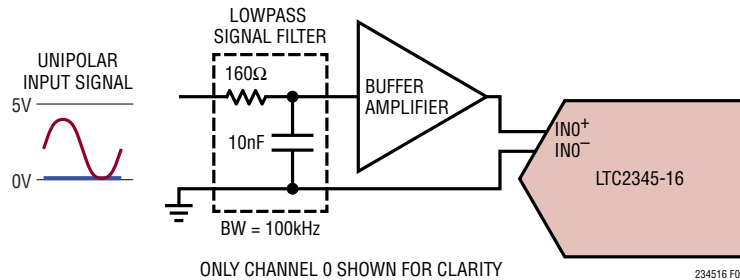

Figure 5. Unipolar Signal Chain with Input Filtering

enough to allow the analog inputs to completely settle to 16-bit resolution within the ADC acquisition time (t_{ACQ}), as insufficient settling can limit INL and THD performance. Also note that the minimum acquisition time varies with sampling frequency (f_{SAMPL}) and the number of enabled channels.

High quality capacitors and resistors should be used in the RC filters since these components can add distortion. NPO/COG and silver mica type dielectric capacitors have excellent linearity. Carbon surface mount resistors can generate distortion from self-heating and from damage that may occur during soldering. Metal film surface mount resistors are much less susceptible to both problems.

Buffering Arbitrary and Fully Differential Analog Input Signals

The wide common mode input range and high CMRR of the LTC2345-16 allow each channel's IN^+ and IN^- pins to swing with an arbitrary relationship to each other, provided each pin remains between ground and V_{DD} . This unique feature of the LTC2345-16 enables it to accept a wide variety of signal swings, simplifying signal chain

design. In many applications, connecting a channel's IN^+ and IN^- pins directly to the existing signal chain circuitry will not allow the channel's sampling network to settle to 16-bit resolution within the ADC acquisition time (t_{ACQ}). In these cases, it is recommended that two unity-gain buffers be inserted between the signal source and the ADC input pins, as shown in Figure 6a. Table 2 lists several amplifier and lowpass filter combinations recommended for use in this circuit. The LT6237 combines fast settling, high linearity, and low offset with $1.1\text{nV}/\sqrt{\text{Hz}}$ input-referred noise density, enabling it to achieve the full ADC data sheet SNR and THD specifications, as shown in the FFT plots in Figures 6b to 6e. In applications where slightly degraded SNR performance is acceptable, it is possible to drive the LTC2345-16 using the lower-power LT6234. The LT6234 combines fast settling, good linearity, and low offset with $1.9\text{nV}/\sqrt{\text{Hz}}$ input-referred noise density, enabling it to drive the LTC2345-16 with only 0.3dB SNR loss compared with the LT6237 when a 40.2Ω , 1nF filter is employed. As shown in Table 2, the LT6237 may be used without a lowpass filter at a loss of $\leq 1\text{dB}$ SNR due to increased wideband noise.

Table 2. Recommended Amplifier and Filter Combinations for the Buffer Circuits in Figures 6a and 9. AC Performance Measured Using Circuit in Figure 6a, $\pm 4.096\text{V}$ Range for Fully Differential Input Drive, $\pm 2.048\text{V}$ Range for Bipolar Input Drive

AMPLIFIER	R_{FILT} (Ω)	C_{FILT} (nF)	INPUT SIGNAL DRIVE	SNR (dB)	THD (dB)	SINAD (dB)	SFDR (dB)
$\frac{1}{2}$ LT6237	40.2	1	FULLY DIFFERENTIAL	91.0	-114	91.0	115
$\frac{1}{2}$ LT6234	40.2	1	FULLY DIFFERENTIAL	90.7	-114	90.7	115
$\frac{1}{2}$ LT6237	40.2	1	BIPOLAR	85.8	-110	85.8	112
$\frac{1}{2}$ LT6234	40.2	1	BIPOLAR	85.5	-110	85.5	112
$\frac{1}{2}$ LT6237	0	0	BIPOLAR	85.4	-110	85.4	112
$\frac{1}{2}$ LT6234	0	0	BIPOLAR	82.1	-108	82.1	110

234516f

APPLICATIONS INFORMATION

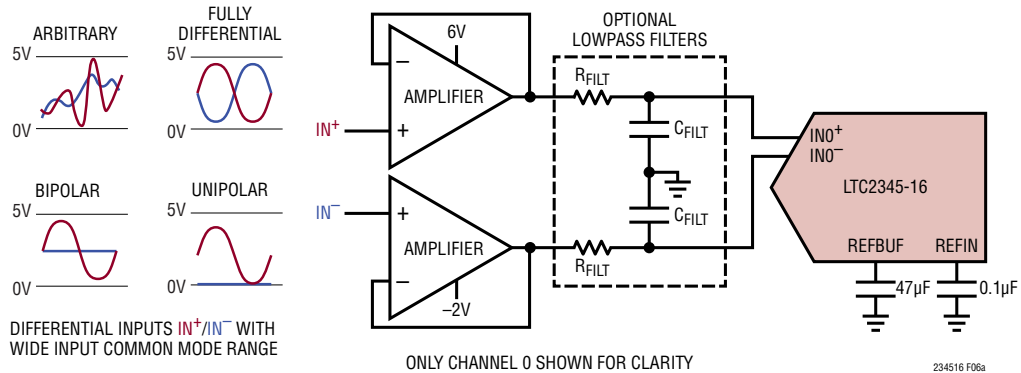

Figure 6a. Buffering Arbitrary, Fully Differential, Bipolar, and Unipolar Signals. See Table 2 For Recommended Amplifier and Filter Combinations

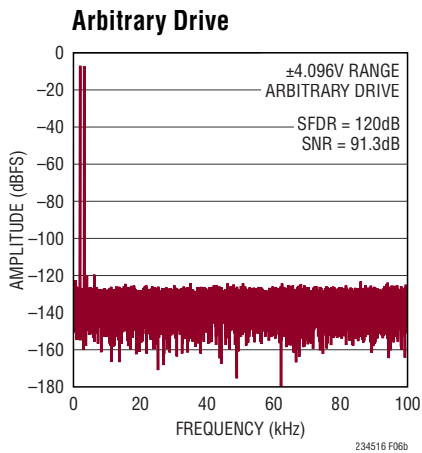

Figure 6b. Two-Tone Test. $IN^+ = -7\text{dBFS}$ 2kHz Sine, $IN^- = -7\text{dBFS}$ 3.1kHz Sine, Common Mode = 2.5V, 32k Point FFT, $f_{\text{SMPL}} = 200\text{kpsps}$. Circuit Shown in Figure 6a with LT6237 Amplifiers, $R_{\text{FILT}} = 40.2\Omega$, $C_{\text{FILT}} = 1\text{nF}$

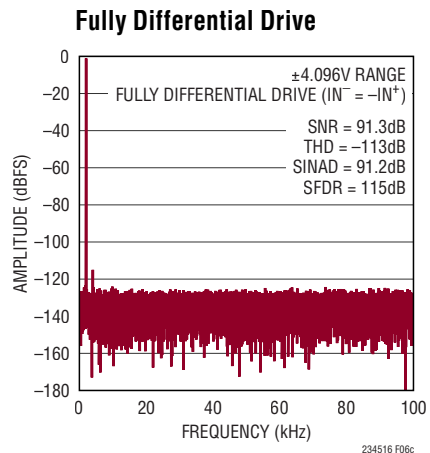

Figure 6c. $IN^+/IN^- = -1\text{dBFS}$ 2kHz Fully Differential Sine, Common Mode = 2.5V, 32k Point FFT, $f_{\text{SMPL}} = 200\text{kpsps}$. Circuit Shown in Figure 6a with LT6237 Amplifiers, $R_{\text{FILT}} = 40.2\Omega$, $C_{\text{FILT}} = 1\text{nF}$

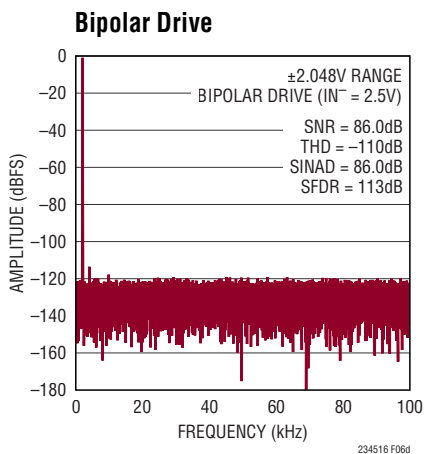

Figure 6d. $IN^+ = -1\text{dBFS}$ 2kHz Bipolar Sine, $IN^- = 2.5\text{V}$, 32k Point FFT, $f_{\text{SMPL}} = 200\text{kpsps}$. Circuit Shown in Figure 6a with LT6237 Amplifiers, $R_{\text{FILT}} = 40.2\Omega$, $C_{\text{FILT}} = 1\text{nF}$

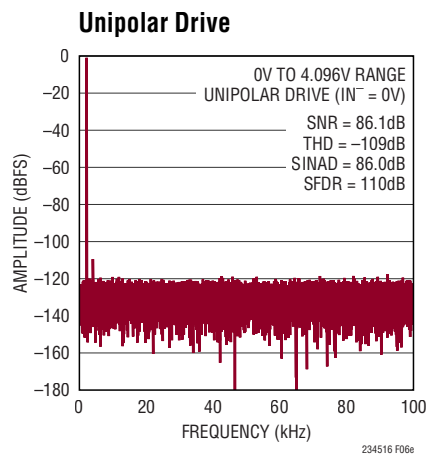

Figure 6e. $IN^+ = -1\text{dBFS}$ 2kHz Unipolar Sine, $IN^- = 0\text{V}$, 32k Point FFT, $f_{\text{SMPL}} = 200\text{kpsps}$. Circuit Shown in Figure 6a with LT6237 Amplifiers, $R_{\text{FILT}} = 40.2\Omega$, $C_{\text{FILT}} = 1\text{nF}$

APPLICATIONS INFORMATION

The two-tone test shown in Figure 6b demonstrates the arbitrary input drive capability of the LTC2345-16. This test simultaneously drives IN⁺ with a -7dBFS 2kHz single-ended sine wave and IN⁻ with a -7dBFS 3.1kHz single-ended sine wave. Together, these signals sweep the analog inputs across a wide range of common mode and differential mode voltage combinations, similar to the more general arbitrary input signal case. They also have a simple spectral representation. An ideal differential converter with no common-mode sensitivity will digitize this signal as two -7dBFS spectral tones, one at each sine wave frequency. The FFT plot in Figure 6b demonstrates the LTC2345-16 response approaches this ideal, with 120dB of SFDR limited by the converter's second harmonic distortion response to the 2kHz sine wave on IN⁺.

The ability of the LTC2345-16 to accept arbitrary signal swings over a wide input common mode range with high CMRR can simplify application solutions. Figure 7 depicts one way of using the LTC2345-16 to digitize signals of this type. Two channels of the LTC2345-16 simultaneously sense the voltage on and bidirectional current through a sense resistor over a wide common mode range. In many applications of this type, the impedance of the external circuitry is low enough that the ADC sampling network can fully settle without buffering.

The common mode input range of the LTC2345-16 includes V_{DD}, allowing the circuit shown in Figure 8a to amplify and measure a load current (I_{LOAD}) from a single 5V supply. Figure 8b shows a measured transient supply current step of an LTC3207 LED driver load. Note the LTC6252 supplies limit the usable current sense range of this circuit to 50mA to 450mA.

Figure 9a illustrates a more general method of amplifying an input signal. The amplifier stage provides a differential gain of approximately 10V/V to the desired sensor signal while the unwanted common mode signal is attenuated by the ADC CMRR. Figure 9b shows measured CMRR performance of this solution, which is competitive with the best commercially available instrumentation amplifiers.

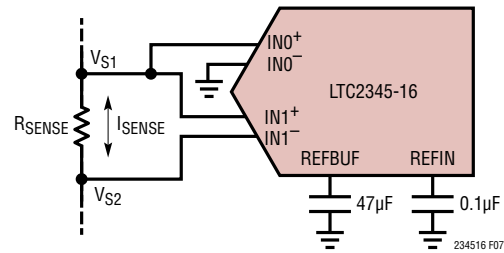

ONLY CHANNELS 0 AND 1 SHOWN FOR CLARITY

$$I_{SENSE} = \frac{V_{S1} - V_{S2}}{R_{SENSE}} \quad \begin{matrix} 0V \leq V_{S1} \leq 5V \\ 0V \leq V_{S2} \leq 5V \end{matrix}$$

Figure 7. Simultaneously Sense Voltage (CH0) and Current (CH1) Over a Wide Common Mode Range

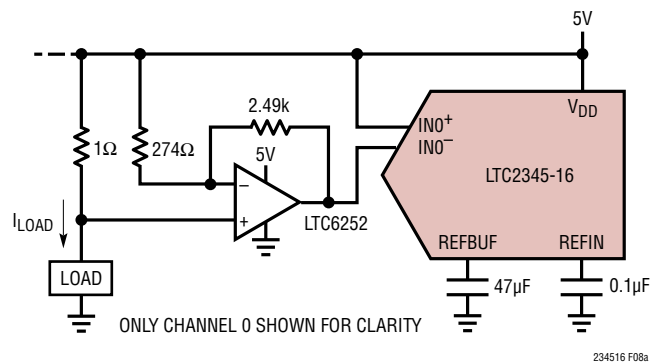

ONLY CHANNEL 0 SHOWN FOR CLARITY

Figure 8a. Sense 50mA to 450mA Current from Single 5V Supply with Amplification

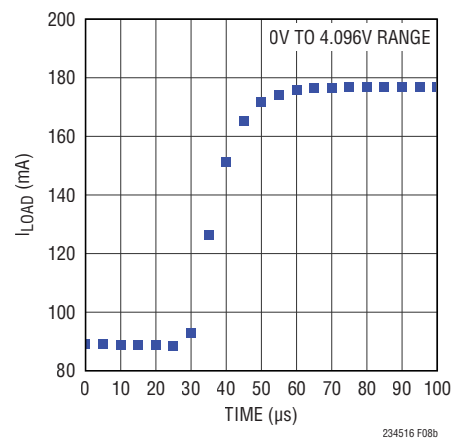

Figure 8b. Transient Supply Current Step Measured Using Circuit in Figure 8a Loaded with LTC3207 LED Driver

APPLICATIONS INFORMATION

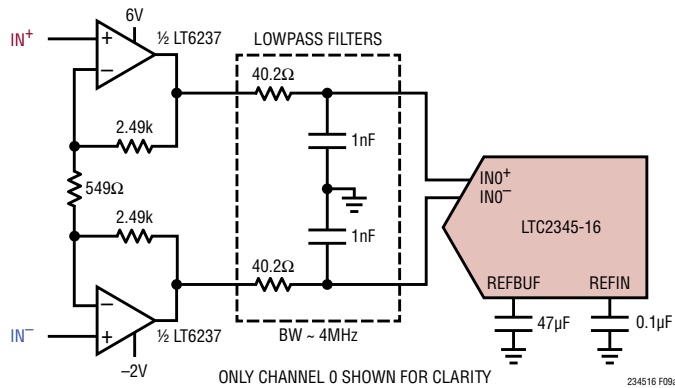

Figure 9a. Digitize Differential Signals with High CMRR

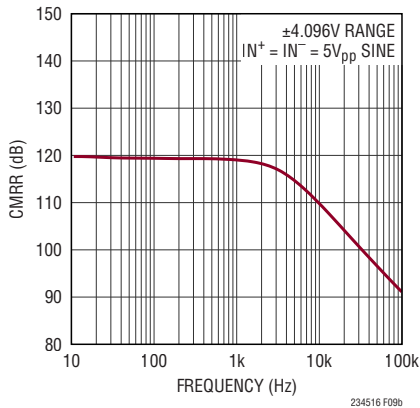

Figure 9b. CMRR vs Input Frequency. Circuit Shown in Figure 9a

Buffering Single-Ended Analog Input Signals

While the circuit shown in Figure 6a is capable of buffering single-ended input signals, the circuit shown in Figure 10 is preferable when the single-ended signal reference level is inherently low impedance and doesn't require buffering. This circuit eliminates one driver and lowpass filter, reducing part count, power dissipation, and SNR degradation due to driver noise. Using the recommended driver and filter combinations in Table 2, the performance of this circuit with single-ended input signals is on par with the performance of the circuit in Figure 6a.

ADC REFERENCE

As shown previously in Table 1b, the LTC2345-16 supports three reference configurations. The first uses both the internal bandgap reference and reference buffer. The second externally overdrives the internal reference but retains the internal buffer, which isolates the external reference from ADC conversion transients. This configuration is ideal for sharing a single precision external reference across multiple ADCs. The third disables the internal buffer and overdrives the REFBUF pin externally.

Internal Reference with Internal Buffer

The LTC2345-16 has an on-chip, low noise, low drift (20ppm/°C maximum), temperature compensated band-gap reference that is factory trimmed to 2.048V. The reference output connects through a 20kΩ resistor to

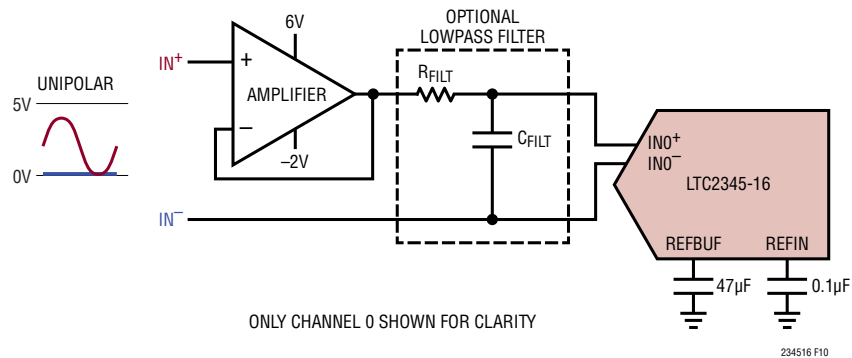

Figure 10. Buffering Single-Ended Input Signals. See Table 2 For Recommended Amplifier and Filter Combinations

APPLICATIONS INFORMATION

the REFIN pin, which serves as the input to the on-chip reference buffer, as shown in Figure 11a. When employing the internal bandgap reference, the REFIN pin should be bypassed to GND (Pin 20) close to the pin with a $0.1\mu\text{F}$ ceramic capacitor to filter wideband noise. The reference buffer amplifies V_{REFIN} to create the converter master reference voltage $V_{\text{REFBUF}} = 2 \cdot V_{\text{REFIN}}$ on the REFBUF pin, nominally 4.096V when using the internal bandgap reference. Bypass REFBUF to GND (Pin 20) close to the pin with at least a $47\mu\text{F}$ ceramic capacitor (X7R, 10V, 1210 size or X5R, 10V, 0805 size) to compensate the reference buffer, absorb transient conversion currents, and minimize noise.

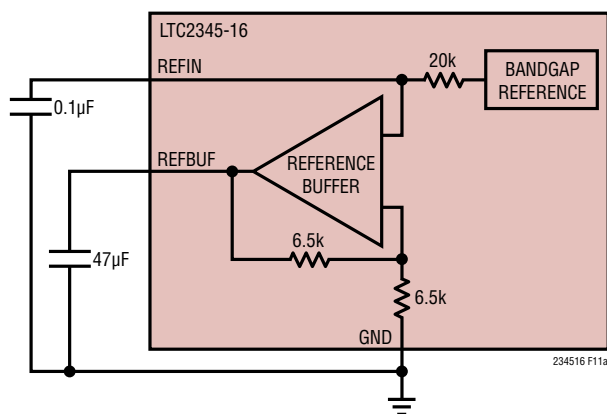

Figure 11a. Internal Reference with Internal Buffer Configuration

External Reference with Internal Buffer

If more accuracy and/or lower drift is desired, REFIN can be easily overdriven by an external reference since $20\text{k}\Omega$ of resistance separates the internal bandgap reference output from the REFIN pin, as shown in Figure 11b. The valid range of external reference voltage overdrive on the REFIN pin is 1.25V to 2.2V , resulting in converter master reference voltages V_{REFBUF} between 2.5V and 4.4V , respectively. Linear Technology offers a portfolio of high performance references designed to meet the needs of many applications. With its small size, low power, and high accuracy, the LTC6655-2.048 is well suited for use with the LTC2345-16 when overdriving the internal reference. The LTC6655-2.048 offers 0.025% (maximum) initial accuracy and $2\text{ppm}/^\circ\text{C}$ (maximum) temperature coefficient for high precision applications. The LTC6655-2.048 is fully specified over the H-grade temperature range, complementing the extended temperature range of the LTC2345-16 up to 125°C . Bypassing the LTC6655-2.048 with a $2.7\mu\text{F}$ to $100\mu\text{F}$ ceramic capacitor close to the REFIN pin is recommended.

External Reference with Disabled Internal Buffer

The internal reference buffer supports $V_{\text{REFBUF}} = 4.4\text{V}$ maximum. By grounding REFIN, the internal buffer may be disabled allowing REFBUF to be overdriven with an external reference voltage between 2.5V and 5V , as shown

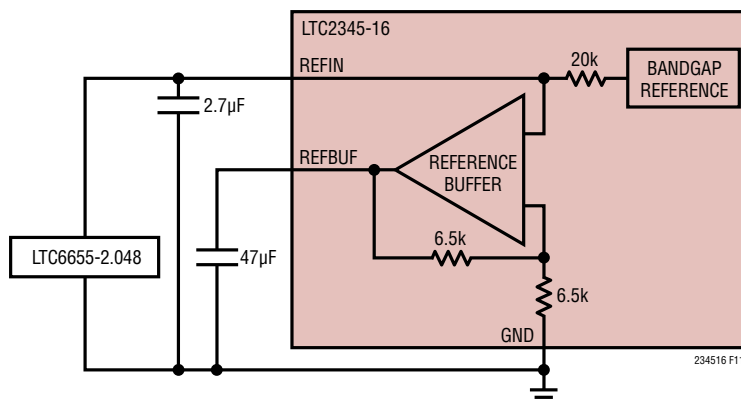

Figure 11b. External Reference with Internal Buffer Configuration

APPLICATIONS INFORMATION

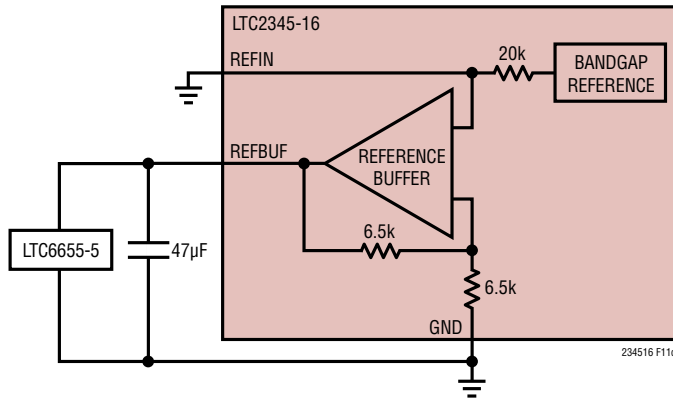

Figure 11c. External Reference with Disabled Internal Buffer Configuration

in Figure 11c. Maximum input signal swing and SNR are achieved by overdriving REFBUF using an external 5V reference. The buffer feedback resistors load the REFBUF pin with 13k Ω even when the reference buffer is disabled. The LTC6655-5 offers the same small size, accuracy, drift, and extended temperature range as the LTC6655-2.048, and achieves a typical SNR of 92dB when paired with the LTC2345-16. Bypass the LTC6655-5 to GND (Pin 20) close to the REFBUF pin with at least a 47 μ F ceramic capacitor (X7R, 10V, 1210 size or X5R, 10V, 0805 size) to absorb transient conversion currents and minimize noise.

The LTC2345-16 converter draws a charge (Q_{CONV}) from the REFBUF pin during each conversion cycle. On short time scales most of this charge is supplied by the external REFBUF bypass capacitor, but on longer time scales all of the charge is supplied by either the reference buffer, or when the internal reference buffer is disabled, the external reference. This charge draw corresponds to a DC current equivalent of $I_{REFBUF} = Q_{CONV} \cdot f_{SMPL}$, which is proportional to sample rate. In applications where a burst of samples is taken after idling for long periods of time, as shown in Figure 12, I_{REFBUF} quickly transitions from approximately 0.4mA to 1.5mA ($V_{REFBUF} = 5V$, $f_{SMPL} = 200kHz$). This current step triggers a transient response in the external reference that must be considered, since any deviation in V_{REFBUF} affects converter accuracy. If an external reference is used to overdrive REFBUF, the fast settling LTC6655 family of references is recommended.

Internal Reference Buffer Transient Response

For optimum performance in applications employing burst sampling, the external reference with internal reference buffer configuration should be used. The internal reference buffer incorporates a proprietary design that minimizes movements in V_{REFBUF} when responding to a burst of

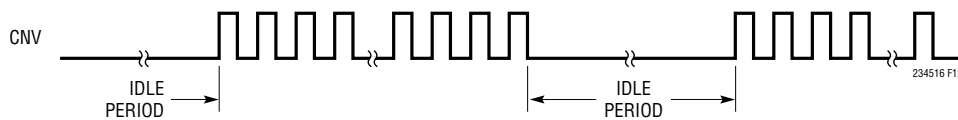

Figure 12. CNV Waveform Showing Burst Sampling

APPLICATIONS INFORMATION

conversions following an idle period. Figure 13 compares the burst conversion response of the LTC2345-16 with an input near full scale for two reference configurations. The first configuration employs the internal reference buffer with REFIN externally overdriven by an LTC6655-2.048, while the second configuration disables the internal reference buffer and overdrives REFBUF with an external LTC6655-4.096. In both cases REFBUF is bypassed to GND with a 47 μ F ceramic capacitor.

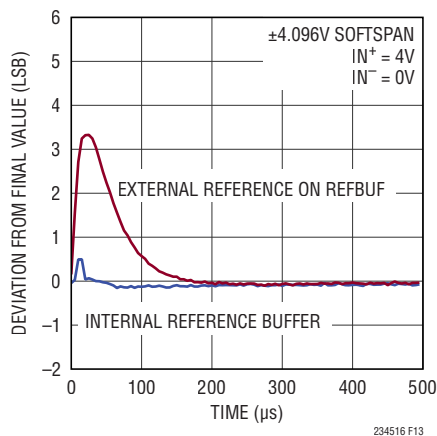

Figure 13. Burst Conversion Response of the LTC2345-16,
 $f_{\text{SMPL}} = 200\text{kpsps}$

DYNAMIC PERFORMANCE

Fast Fourier transform (FFT) techniques are used to test the ADC's frequency response, distortion, and noise at the rated throughput. By applying a low distortion sine wave and analyzing the digital output using an FFT algorithm, the ADC's spectral content can be examined for frequencies outside the fundamental. The LTC2345-16 provides guaranteed tested limits for both AC distortion and noise measurements.

Signal-to-Noise and Distortion Ratio (SINAD)

The signal-to-noise and distortion ratio (SINAD) is the ratio between the RMS amplitude of the fundamental input frequency and the RMS amplitude of all other frequency components at the A/D output. The output is band-limited

to frequencies below half the sampling frequency, excluding DC. Figure 14 shows that the LTC2345-16 achieves a typical SINAD of 91.1dB in the $\pm 4.096\text{V}$ range at a 200kHz sampling rate with a fully differential 2kHz input signal.

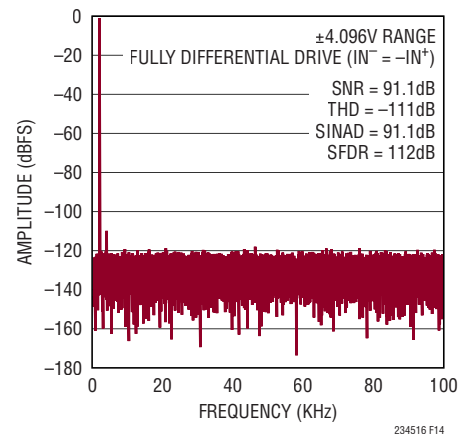

Figure 14. 32k Point FFT $f_{\text{SMPL}} = 200\text{kpsps}$, $f_{\text{IN}} = 2\text{kHz}$

Signal-to-Noise Ratio (SNR)

The signal-to-noise ratio (SNR) is the ratio between the RMS amplitude of the fundamental input frequency and the RMS amplitude of all other frequency components except the first five harmonics and DC. Figure 14 shows that the LTC2345-16 achieves a typical SNR of 91.1dB in the $\pm 4.096\text{V}$ range at a 200kHz sampling rate with a fully differential 2kHz input signal.

Total Harmonic Distortion (THD)

Total harmonic distortion (THD) is the ratio of the RMS sum of all harmonics of the input signal to the fundamental itself. The out-of-band harmonics alias into the frequency band between DC and half the sampling frequency ($f_{\text{SMPL}}/2$). THD is expressed as:

$$\text{THD} = 20 \log \frac{\sqrt{V_2^2 + V_3^2 + V_4^2 \dots V_N^2}}{V_1}$$

where V_1 is the RMS amplitude of the fundamental frequency and V_2 through V_N are the amplitudes of the second through Nth harmonics, respectively. Figure 14 shows

APPLICATIONS INFORMATION

that the LTC2345-16 achieves a typical THD of -111dB ($N = 6$) in the $\pm 4.096\text{V}$ range at a 200kHz sampling rate with a fully differential 2kHz input signal.

POWER CONSIDERATIONS

The LTC2345-16 provides two power supply pins: the 5V core power supply (V_{DD}) and the digital input/output (I/O) interface power supply (OV_{DD}). The flexible OV_{DD} supply allows the LTC2345-16 to communicate with CMOS logic operating between 1.8V and 5V , including 2.5V and 3.3V systems. When using LVDS I/O mode, the range of OV_{DD} is 2.375V to 5.25V .

Power Supply Sequencing

The LTC2345-16 does not have any specific power supply sequencing requirements. Care should be taken to adhere to the maximum voltage relationships described in the Absolute Maximum Ratings section. The LTC2345-16 has an internal power-on-reset (POR) circuit which resets the converter on initial power-up and whenever V_{DD} drops below 2V . Once the supply voltage re-enters the nominal supply voltage range, the POR reinitializes the ADC. No conversions should be initiated until at least 10ms after a POR event to ensure the initialization period has ended. When employing the internal reference buffer, allow 200ms for the buffer to power up and recharge the REFBUF bypass capacitor. Any conversion initiated before these times will produce invalid results.

TIMING AND CONTROL

CNV Timing

The LTC2345-16 sampling and conversion is controlled by CNV. A rising edge on CNV transitions all channels' S/H circuits from track mode to hold mode, simultaneously sampling the input signals on all channels and initiating a conversion. Once a conversion has been started, it cannot be terminated early except by resetting the ADC, as discussed in the Reset Timing section. For optimum performance, drive CNV with a clean, low jitter signal and

avoid transitions on data I/O lines leading up to the rising edge of CNV. Additionally, to minimize channel-to-channel crosstalk, avoid high slew rates on the analog inputs for 100ns before and after the rising edge of CNV. Converter status is indicated by the BUSY output, which transitions low-to-high at the start of each conversion and stays high until the conversion is complete. Once CNV is brought high to begin a conversion, it should be returned low between 40ns and 60ns later or after the falling edge of BUSY to minimize external disturbances during the internal conversion process. If CNV is returned low after the falling edge of BUSY, it should be held low for at least 420ns before bringing it high again, since the converter acquisition time (t_{ACQ}) is set by the CNV low time (t_{CNVL}) in this case.

Internal Conversion Clock

The LTC2345-16 has an internal clock that is trimmed to achieve a maximum conversion time of $555 \cdot N - 35\text{ns}$ with N channels enabled. With a minimum acquisition time of 565ns when converting eight channels simultaneously, throughput performance of 200ksp s is guaranteed without any external adjustments.

Power Down Mode

When PD is brought high, the LTC2345-16 is powered down and subsequent conversion requests are ignored. If this occurs during a conversion, the device powers down once the conversion completes. In this mode, the device draws only a small regulator standby current resulting in a typical power dissipation of 0.33mW . To exit power down mode, bring the PD pin low and wait at least 10ms before initiating a conversion. When employing the internal reference buffer, allow 200ms for the buffer to power up and recharge the REFBUF bypass capacitor. Any conversion initiated before these times will produce invalid results.

Reset Timing

A global reset of the LTC2345-16, equivalent to a power-on-reset event, may be executed without needing to cycle the supplies. This feature is useful when recovering from system-level events that require the state of the entire sys-

APPLICATIONS INFORMATION

tem to be reset to a known synchronized value. To initiate a global reset, bring PD high twice without an intervening conversion, as shown in Figure 15. The reset event is triggered on the second rising edge of PD, and asynchronously ends based on an internal timer. Reset clears all serial data output registers and restores the internal SoftSpan configuration register default state of all channels in SoftSpan 7. If reset is triggered during a conversion, the conversion is immediately halted. The normal power down behavior associated with PD going high is not affected by reset. Once PD is brought low, wait at least 10ms before initiating a conversion. When employing the internal reference buffer, allow 200ms for the buffer to power up and recharge the REFBUF bypass capacitor. Any conversion initiated before these times will produce invalid results.

Auto Nap Mode

The LTC2345-16 automatically enters nap mode after a conversion has finished and completely powers up once a new conversion is initiated on the rising edge of CNV. Auto nap mode causes the power dissipation of the LTC2345-16 to decrease as the sampling frequency is reduced, as shown in Figure 16. This decrease in average power dissipation occurs because a portion of the LTC2345-16 circuitry is turned off during nap mode, and the fraction of the conversion cycle (t_{CYC}) spent napping increases as the sampling frequency (f_{SAMPL}) is decreased.

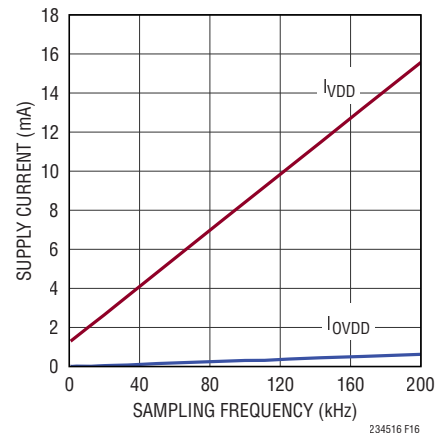

Figure 16. Power Dissipation of the LTC2345-16 Decreases with Decreasing Sampling Frequency

DIGITAL INTERFACE

The LTC2345-16 features CMOS and LVDS serial interfaces, selectable using the LVDS/CMOS pin. The flexible OV_{DD} supply allows the LTC2345-16 to communicate with any CMOS logic operating between 1.8V and 5V, including 2.5V and 3.3V systems, while the LVDS interface supports low noise digital designs. In CMOS mode, applications may employ between one and eight lanes of serial data output, allowing the user to optimize bus width and data

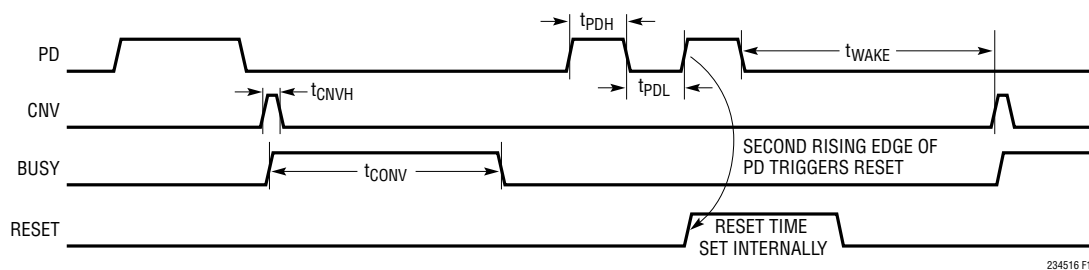

Figure 15. Reset Timing for the LTC2345-16

APPLICATIONS INFORMATION

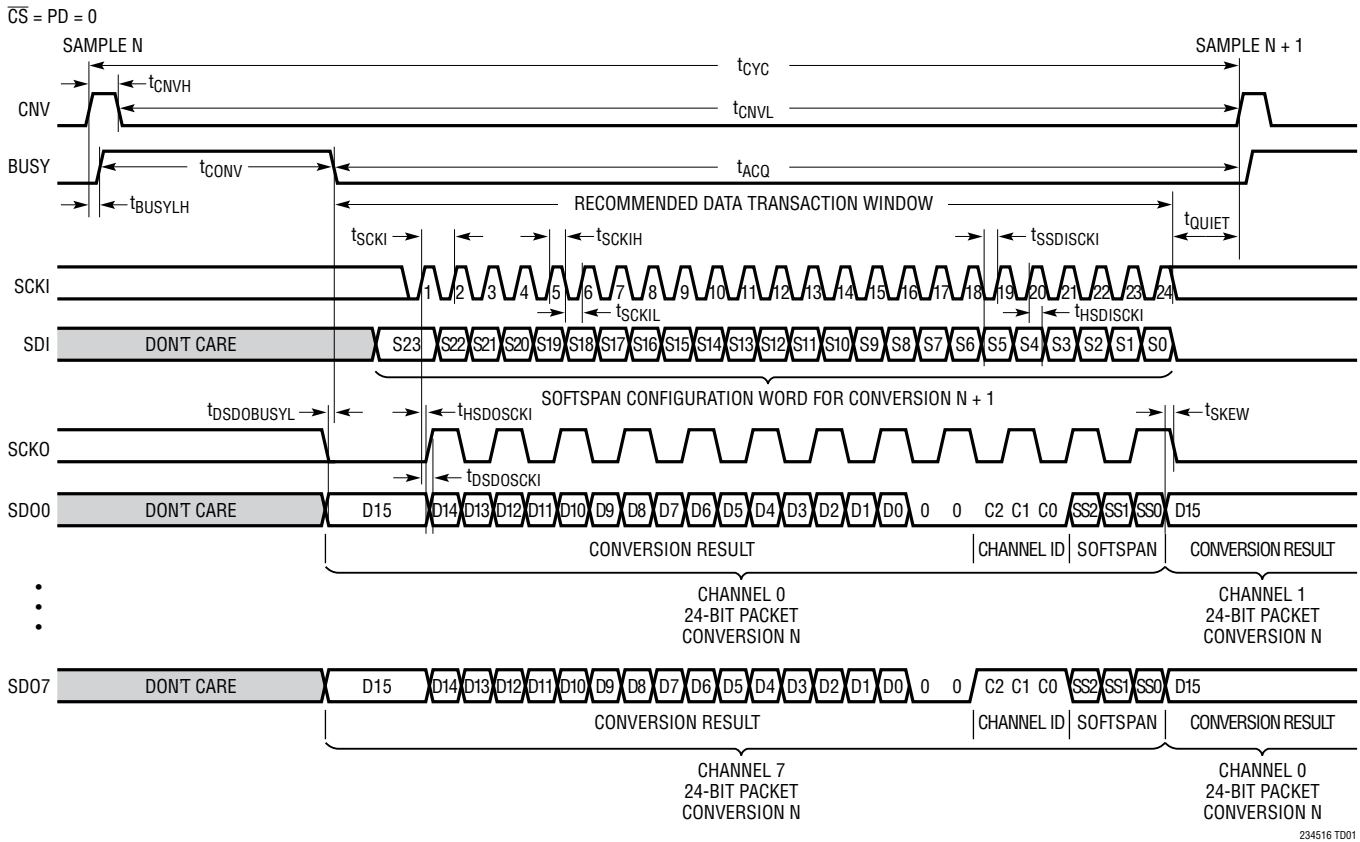

Figure 17. Serial CMOS I/O Mode

throughput. Together, these I/O interface options enable the LTC2345-16 to communicate equally well with legacy microcontrollers and modern FPGAs.

Serial CMOS I/O Mode

As shown in Figure 17, in CMOS I/O mode the serial data bus consists of a serial clock input, SCKI, serial data input, SDI, serial clock output, SCKO, and eight lanes of serial data output, SD00 to SD07. Communication with the LTC2345-16 across this bus occurs during predefined data transaction windows. Within a window, the device accepts 24-bit SoftSpan configuration words for the next conversion on SDI and outputs 24-bit packets containing conversion results and channel configuration information from the previous conversion on SD00 to SD07. New data transaction windows open 10ms after powering up or resetting the LTC2345-16, and at the end of each conversion on the falling edge of BUSY. In the recommended

use case, the data transaction should be completed with a minimum t_{QUIET} time of 20ns prior to the start of the next conversion, as shown in Figure 17. New SoftSpan configuration words are only accepted within this recommended data transaction window, but SoftSpan changes take effect immediately with no additional analog input settling time required before starting the next conversion. It is still possible to read conversion data after starting the next conversion, but this will degrade conversion accuracy and therefore is not recommended.

Just prior to the falling edge of BUSY and the opening of a new data transaction window, SCKO is forced low and SD00 to SD07 are updated with the latest conversion results from analog input channels 0 to 7, respectively. Rising edges on SCKI serially clock conversion results on SD00 to SD07 and trigger transitions on SCKO that are skew-matched to the data on SD00 to SD07. The resulting

APPLICATIONS INFORMATION

SCKO frequency is half that of SCKI. SCKI rising edges also latch SoftSpan configuration words provided on SDI, which are used to program the internal 24-bit SoftSpan configuration register. See the section Programming the SoftSpan Configuration Register in CMOS I/O Mode for further details. SCKI is allowed to idle either high or low in CMOS I/O mode. As shown in Figure 18, the CMOS bus is enabled when \overline{CS} is low and is disabled and Hi-Z when \overline{CS} is high, allowing the bus to be shared across multiple devices.

The data on SDO0 to SDO7 are grouped into 24-bit packets consisting of a 16-bit conversion result plus 2-bit trailing zero pad, 3-bit analog channel ID, and 3-bit SoftSpan code, all presented MSB first. As suggested in Figures 17 and 18, each SDO lane outputs these packets for all analog input channels in a sequential, circular manner. For example, the first 24-bit packet output on SDO0 corresponds to analog input channel 0, followed by the packets for channels 1 through 7. The data output on SDO0 then wraps back to channel 0, and this pattern repeats indefinitely. Other SDO lanes follow a similar circular pattern, except the first packet presented on each lane corresponds to its associated analog input channel.

When interfacing the LTC2345-16 with a standard SPI bus, capture output data at the receiver on rising edges of SCKI. SCKO is not used in this case. Multiple SDO lanes

are also usually not useful in this case. In other applications, such as interfacing the LTC2345-16 with an FPGA or CPLD, rising and falling edges of SCKO may be used to capture serial output data on SDO0 to SDO7 in double data rate (DDR) fashion. Capturing data using SCKO adds robustness to delay variations over temperature and supply.

Full Eight Lane Serial CMOS Output Data Capture

As shown in Table 3, full 200ksps per channel throughput can be achieved with a 45MHz SCKI frequency by capturing the first packet (24 SCKI cycles total) from all eight serial data output lanes SDO0 to SDO7. This configuration also allows conversion results from all channels to be captured using as few as 16 SCKI cycles if the 3-bit analog channel ID and 3-bit SoftSpan code are not needed and the device SoftSpan configuration is not being changed. Multi-lane data capture is usually best suited for use with FPGA or CPLD capture hardware, but may be useful in other application-specific cases.

Fewer Than Eight Lane Serial CMOS Output Data Capture

Applications that cannot accommodate the full eight lanes of serial data capture may employ fewer lanes without reconfiguring the LTC2345-16. For example, capturing the first two packets (48 SCKI cycles total) from SDO0, SDO2, SDO4, and SDO6 provides data for analog input

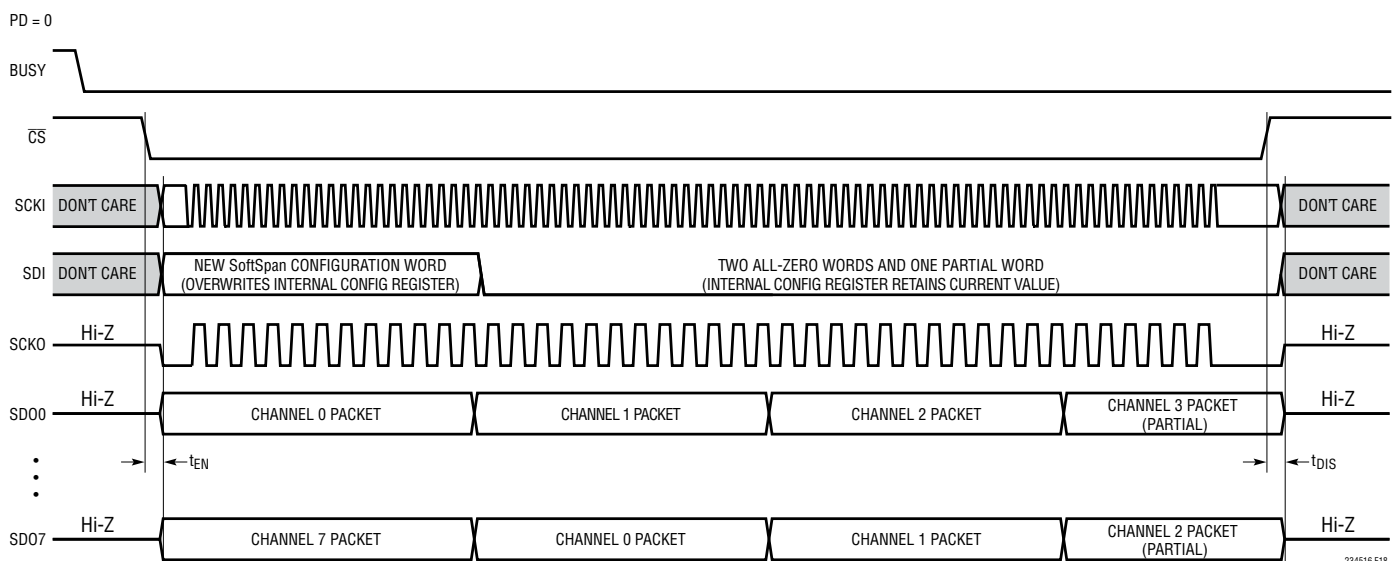

Figure 18. Internal SoftSpan Configuration Register Behavior. Serial CMOS Bus Response to \overline{CS}

234516f

APPLICATIONS INFORMATION

channels 0 and 1, 2 and 3, 4 and 5, and 6 and 7, respectively, using four output lanes. Similarly, capturing the first four packets (96 SCKI cycles total) from SDO0 and SDO4 provides data for analog input channels 0 to 3 and 4 to 7, respectively, using two output lanes. If only one lane can be accommodated, capturing the first eight packets (192 SCKI cycles total) from SDO0 provides data for all analog input channels. As shown in Table 3, full 200ksp per channel throughput can be achieved with a 90MHz SCKI frequency in the four lane case, but the maximum CMOS SCKI frequency of 100MHz limits the throughput to less than 200ksp per channel in the two lane and one lane cases. Finally, note that in choosing the number of lanes and which lanes to use for data capture, the user is not restricted to the specific cases mentioned above. Other choices may be more optimal in particular applications.

Programming the SoftSpan Configuration Register in CMOS I/O Mode

The internal 24-bit SoftSpan configuration register controls the SoftSpan range for all analog input channels of the LTC2345-16. The default state of this register after power-up or resetting the device is all ones, configuring each channel to convert in SoftSpan 7, the $\pm V_{REFBUF}$ range (see Table 1a). The state of this register may be modified by providing a new 24-bit SoftSpan configuration word on SDI during the data transaction window shown in Figure 17. New SoftSpan configuration words are only accepted within this recommended data transaction window, but SoftSpan changes take effect immediately with no additional analog input settling time required before starting

the next conversion. Setting a channel's SoftSpan code to SS[2:0] = 000 immediately disables the channel, resulting in a corresponding reduction in t_{CONV} on the next conversion. Similarly, enabling a previously disabled channel requires no additional analog input settling time before starting the next conversion. The mapping between the serial SoftSpan configuration word, the internal SoftSpan configuration register, and each channel's 3-bit SoftSpan code is illustrated in Figure 19.

If fewer than 24 SCKI rising edges are provided during a data transaction window, the partial word received on SDI will be ignored and the SoftSpan configuration register will not be updated. If exactly 24 SCKI rising edges are provided, the SoftSpan configuration register will be updated to match the received SoftSpan configuration word, S[23:0]. The one exception to this behavior occurs when S[23:0] is all zeros. In this case, the SoftSpan configuration register will not be updated, allowing applications to retain the current SoftSpan configuration state by idling SDI low. If more than 24 SCKI rising edges are provided during a data transaction window, each complete 24-bit word received on SDI will be interpreted as a new SoftSpan configuration word and applied to the SoftSpan configuration register as described above. Any partial words are ignored.

Typically, applications will update the SoftSpan configuration register in the manner shown in Figures 17 and 18. After the opening of a new data transaction window at the falling edge of BUSY, the user supplies a 24-bit SoftSpan configuration word on SDI during the first 24 SCKI cycles. This new word overwrites the internal configuration register

Table 3. Required SCKI Frequency to Achieve Various Throughputs in Common Output Bus Configurations with Eight Channels Enabled. Shaded Entries Denote Throughputs That Are Not Achievable in a Given Configuration. Calculated Using $f_{SCKI} = (\text{Number of SCKI Cycles}) / (t_{ACQ,MIN} - t_{QUIET})$

I/O MODE	NUMBER OF SDO LANES	NUMBER OF SCKI CYCLES	REQUIRED f_{SCKI} (MHz) TO ACHIEVE THROUGHPUT OF		
			200ksp/CHANNEL ($t_{ACQ} = 565\text{ns}$)	100ksp/CHANNEL ($t_{ACQ} = 565\text{ns}$)	50ksp/CHANNEL ($t_{ACQ} = 1565\text{ns}$)
CMOS	8	16	30	3	2
	8	24	45	5	2
	4	48	90	9	4
	2	96	Not Achievable	18	7
	1	192	Not Achievable	35	13
LVDS	1	96	180 (360Mbps)	18 (36Mbps)	7 (14Mbps)

APPLICATIONS INFORMATION

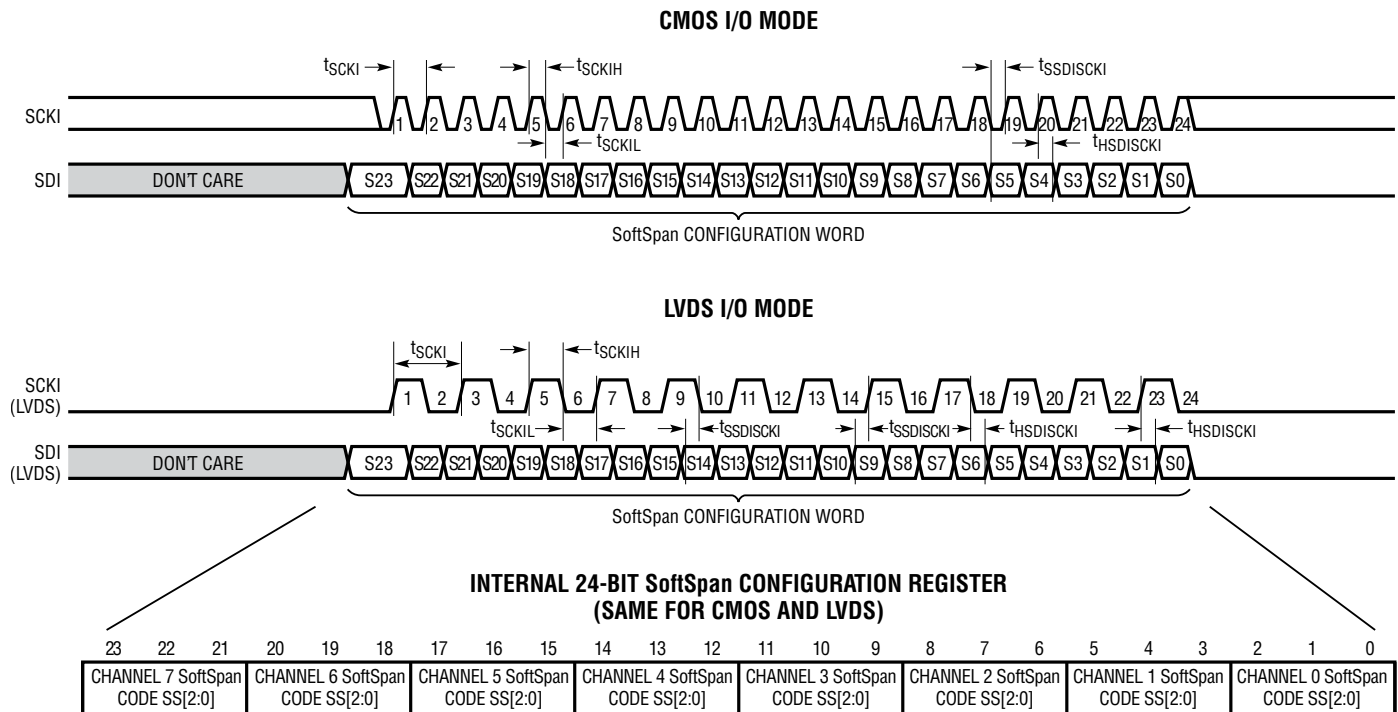

234516 F19

Figure 19. Mapping Between Serial SoftSpan Configuration Word, Internal SoftSpan Configuration Register, and SoftSpan Code for Each Analog Input Channel

contents following the 24th SCKI rising edge. The user then holds SDI low for the remainder of the data transaction window causing the register to retain its contents regardless of the number of additional SCKI cycles applied. SoftSpan settings may be retained across multiple conversions by holding SDI low for the entire data transaction window, regardless of the number of SCKI cycles applied.

Serial LVDS I/O Mode

In LVDS I/O mode, information is transmitted using positive and negative signal pairs (LVDS⁺/LVDS⁻) with bits differentially encoded as (LVDS⁺ – LVDS⁻). These signals are typically routed using differential transmission lines with 100Ω characteristic impedance. Logical 1's and 0's are nominally represented by differential +350mV and –350mV, respectively. For clarity, all LVDS timing diagrams and interface discussions adopt the logical rather than physical convention.

As shown in Figure 20, in LVDS I/O mode the serial data bus consists of a serial clock differential input, SCKI, serial data differential input, SDI, serial clock differential output, SCKO, and serial data differential output, SDO. Communication with the LTC2345-16 across this bus occurs during predefined data transaction windows. Within a window, the device accepts 24-bit SoftSpan configuration words for the next conversion on SDI and outputs 24-bit packets containing conversion results and channel configuration information from the previous conversion on SDO. New data transaction windows open 10ms after powering up or resetting the LTC2345-16, and at the end of each conversion on the falling edge of BUSY. In the recommended use case, the data transaction should be completed with a minimum t_{QUIET} time of 20ns prior to the start of the next conversion, as shown in Figure 20. New SoftSpan configuration words are only accepted within this recommended data transaction window, but SoftSpan changes take effect immediately with no additional analog input

234516f

APPLICATIONS INFORMATION

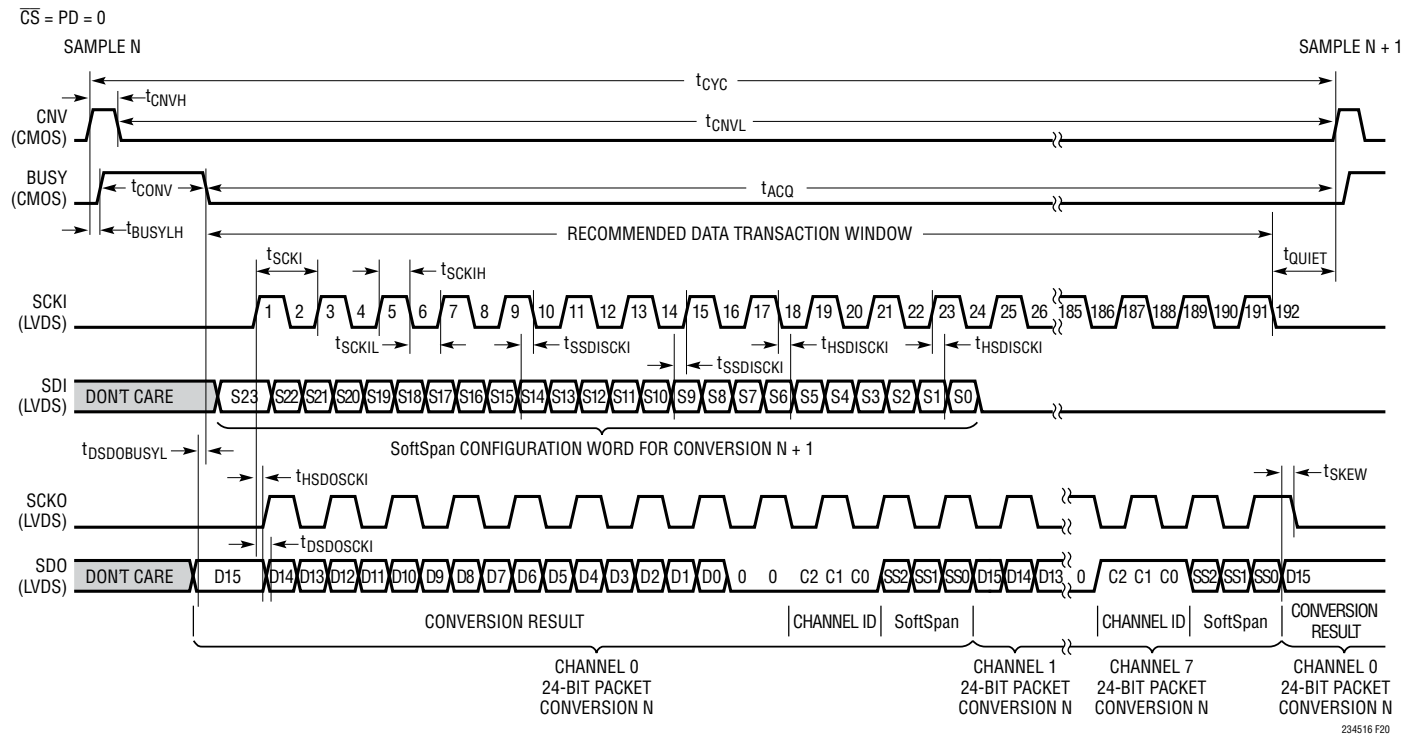

Figure 20. Serial LVDS I/O Mode

settling time required before starting the next conversion. It is still possible to read conversion data after starting the next conversion, but this will degrade conversion accuracy and therefore is not recommended.

Just prior to the falling edge of BUSY and the opening of a new data transaction window, SDO is updated with the latest conversion results from analog input channel 0. Both rising and falling edges on SCKI serially clock conversion results and analog input channel configuration information out on SDO. SCKI is also echoed on SCKO, skew-matched to the data on SDO. Whenever possible, it is recommended that rising and falling edges of SCKO be used to capture DDR serial output data on SDO, as this will yield the best robustness to delay variations over supply and temperature. SCKI rising and falling edges also latch SoftSpan configuration words provided on SDI, which are used to program the internal 24-bit SoftSpan configuration register. See the section Programming the SoftSpan Configuration Register in LVDS I/O Mode for further details. As shown in Figure 21, the LVDS bus is enabled when \overline{CS} is low and is

disabled and Hi-Z when \overline{CS} is high, allowing the bus to be shared across multiple devices. Due to the high speeds involved in LVDS signaling, LVDS bus sharing must be carefully considered. Transmission line limitations imposed by the shared bus may limit the maximum achievable bus clock speed. LVDS inputs are internally terminated with a 100 Ω differential resistor when $\overline{CS} = 0$, while outputs must be differentially terminated with a 100 Ω resistor at the receiver (FPGA). SCKI must idle in the low state in LVDS I/O mode, including when transitioning \overline{CS} .

The data on SDO are grouped into 24-bit packets consisting of a 16-bit conversion result plus 2-bit trailing zero pad, 3-bit analog channel ID, and 3-bit SoftSpan code, all presented MSB first. As suggested in Figures 20 and 21, SDO outputs these packets for all analog input channels in a sequential, circular manner. For example, the first 24-bit packet output on SDO corresponds to analog input channel 0, followed by the packets for channels 1 through 7. The data output on SDO then wraps back to channel 0, and this pattern repeats indefinitely.

APPLICATIONS INFORMATION

Serial LVDS Output Data Capture

As shown in Table 3, full 200ksps per channel throughput can be achieved with a 180MHz SCKI frequency by capturing eight packets (96 SCKI cycles total) of DDR data from SDO. The LTC2345-16 supports LVDS SCKI frequencies up to 250MHz.

Programming the SoftSpan Configuration Register in LVDS I/O Mode

The internal 24-bit SoftSpan configuration register controls the SoftSpan range for all analog input channels of the LTC2345-16. The default state of this register after power-up or resetting the device is all ones, configuring each channel to convert in SoftSpan 7, the $\pm V_{REFBUF}$ range (see Table 1a). The state of this register may be modified by providing a new 24-bit SoftSpan configuration word on SDI during the data transaction window shown in Figure 20. New SoftSpan configuration words are only accepted within this recommended data transaction window, but SoftSpan changes take effect immediately with no additional analog input settling time required before starting the next conversion. Setting a channel's SoftSpan code to SS[2:0] = 000 immediately disables the channel, resulting in a corresponding reduction in t_{CONV} on the next conversion. Similarly, enabling a previously disabled channel requires no additional analog input settling time before starting the next conversion. The mapping between the serial SoftSpan configuration word, the internal SoftSpan configuration register, and each channel's 3-bit SoftSpan code is illustrated in Figure 19.

If fewer than 24 SCKI edges (rising plus falling) are provided during a data transaction window, the partial word received on SDI will be ignored and the SoftSpan configuration register will not be updated. If exactly 24 SCKI edges are provided, the SoftSpan configuration register will be updated to match the received SoftSpan configuration word, S[23:0]. The one exception to this behavior occurs when S[23:0] is all zeros. In this case, the SoftSpan configuration register will not be updated, allowing applications to retain the current SoftSpan configuration state by idling SDI low. If more than 24 SCKI edges are provided during a data transaction window, each complete 24-bit word received on SDI will be interpreted as a new SoftSpan configuration word and applied to the SoftSpan configuration register as described above. Any partial words are ignored.

Typically, applications will update the SoftSpan configuration register in the manner shown in Figures 20 and 21. After the opening of a new data transaction window at the falling edge of BUSY, the user supplies a 24-bit DDR SoftSpan configuration word on SDI during the first 12 SCKI cycles. This new word overwrites the internal configuration register contents following the 12th SCKI falling edge. The user then holds SDI low for the remainder of the data transaction window causing the register to retain its contents regardless of the number of additional SCKI cycles applied. SoftSpan settings may be retained across multiple conversions by holding SDI low for the entire data transaction window, regardless of the number of SCKI cycles applied.

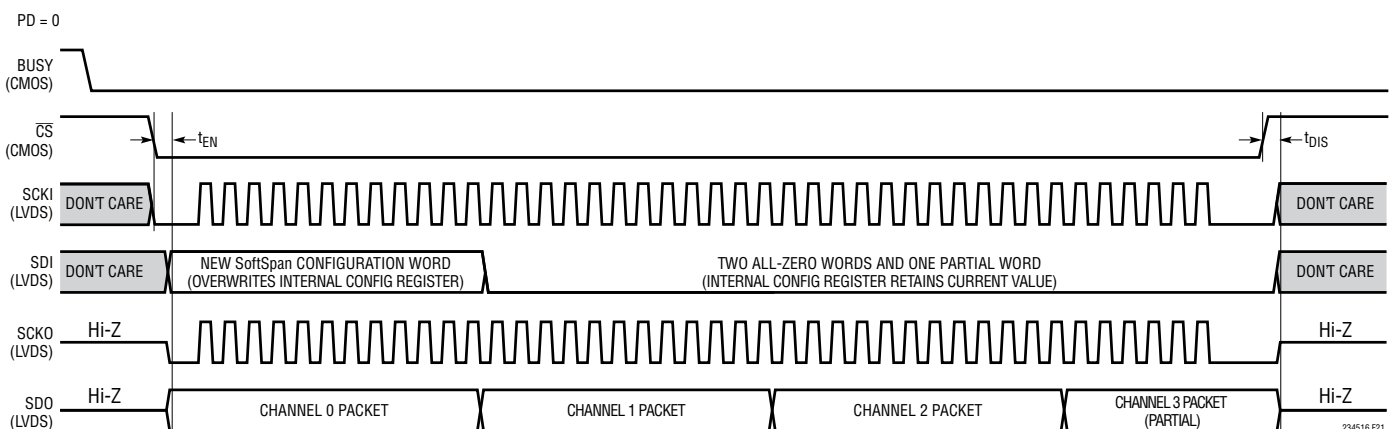

Figure 21. Internal SoftSpan Configuration Register Behavior. Serial LVDS Bus Response to \overline{CS}

234516f

BOARD LAYOUT

To obtain the best performance from the LTC2345-16, a four-layer printed circuit board (PCB) is recommended. Layout for the PCB should ensure the digital and analog signal lines are separated as much as possible. In particular, care should be taken not to run any digital clocks or signals alongside analog signals or underneath the ADC. Also minimize the length of the REFBUF to GND (Pin 20) bypass capacitor return loop, and avoid routing CNV near signals which could potentially disturb its rising edge.

Supply bypass capacitors should be placed as close as possible to the supply pins. Low impedance common returns for these bypass capacitors are essential to the low noise operation of the ADC. A single solid ground plane is recommended for this purpose. When possible, screen the analog input traces using ground.

Reference Design

For a detailed look at the reference design for this converter, including schematics and PCB layout, please refer to [DC2326A](#), the evaluation kit for the LTC2345-16.

TYPICAL APPLICATION

Sense Current from Rail with Amplification

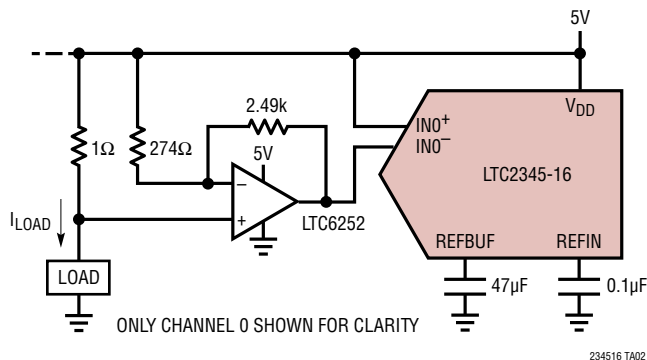

RELATED PARTS

PART NUMBER	DESCRIPTION	COMMENTS
ADCs		
LTC2345-18	18-Bit, 200ksps, 8-Channel Simultaneous Sampling, ± 5 LSB INL, Serial ADC	5V Supply, SoftSpan Inputs with Wide Common Mode Range, 91.8dB SNR, Serial CMOS and LVDS I/O, 7mm \times 7mm QFN-48 Package
LTC2348-18/LTC2348-16	18-/16-Bit, 200ksps, 8-Channel Simultaneous Sampling, $\pm 3/\pm 1$ LSB INL, Serial ADC	± 10.24 V SoftSpan Inputs with Wide Common Mode Range, 97/94dB SNR, Serial CMOS and LVDS I/O, 7mm \times 7mm LQFP-48 Package
LTC2378-20/LTC2377-20/ LTC2376-20	20-Bit, 1Msps/500ksps/250ksps, ± 0.5 ppm INL Serial, Low Power ADC	2.5V Supply, ± 5 V Fully Differential Input, 104dB SNR, MSOP-16 and 4mm \times 3mm DFN-16 Packages
LTC2338-18/LTC2337-18/ LTC2336-18	18-Bit, 1Msps/500ksps/250ksps, Serial, Low Power ADC	5V Supply, ± 10.24 V Fully Differential Input, 100dB SNR, MSOP-16 Package
LTC2328-18/LTC2327-18/ LTC2326-18	18-Bit, 1Msps/500ksps/250ksps, Serial, Low Power ADC	5V Supply, ± 10.24 V Pseudo-Differential Input, 95dB SNR, MSOP-16 Package
LTC2373-18/LTC2372-18	18-Bit, 1Msps/500ksps, 8-Channel, Serial ADC	5V Supply, 8 Channel Multiplexed, Configurable Input Range, 100dB SNR, DGC, 5mm \times 5mm QFN-32 Package
LTC2379-18/LTC2378-18/ LTC2377-18/LTC2376-18	18-Bit, 1.6Msps/1Msps/500ksps/250ksps, Serial, Low Power ADC	2.5V Supply, Differential Input, 101.2dB SNR, ± 5 V Input Range, DGC, Pin Compatible Family in MSOP-16 and 4mm \times 3mm DFN-16 Packages
LTC2380-16/LTC2378-16/ LTC2377-16/LTC2376-16	16-Bit, 2Msps/1Msps/500ksps/250ksps, Serial, Low Power ADC	2.5V Supply, Differential Input, 96.2dB SNR, ± 5 V Input Range, DGC, Pin Compatible Family in MSOP-16 and 4mm \times 3mm DFN-16 Packages
LTC2389-18/LTC2389-16	18-Bit/16-Bit, 2.5Msps, Parallel/Serial ADC	5V Supply, Pin-Configurable Input Range, 99.8dB/96dB SNR, Parallel or Serial I/O 7mm \times 7mm LQFP-48 and QFN-48 Packages
LTC1859/LTC1858/ LTC1857	16-/14-/12-Bit, 8-Channel, 100ksps, Serial ADC	± 10 V, SoftSpan, Single-Ended or Differential Inputs, Single 5V Supply, SSOP-28 Package
LTC1606/LTC1605	16-Bit, 250ksps/100ksps, Parallel ADC	± 10 V Input, 5V Supply, 75mW/55mW, SSOP-28 and SO-28 Packages
DACs		
LTC2756/LTC2757	18-Bit, Serial/Parallel I_{OUT} SoftSpan DAC	± 1 LSB INL/DNL, Software-Selectable Ranges, SSOP-28/7mm \times 7mm LQFP-48 Package
LTC2668	16-Channel 16-/12-Bit ± 10 V V_{OUT} SoftSpan DACs	± 4 LSB INL, Precision Reference 10ppm/ $^{\circ}$ C Max, 6mm \times 6mm QFN-40 Package
References		
LTC6655	Precision Low Drift Low Noise Buffered Reference	5V/2.5V/2.048V/1.25V, 2ppm/ $^{\circ}$ C, 0.25ppm Peak-to-Peak Noise, MSOP-8 Package
LTC6652	Precision Low Drift Low Noise Buffered Reference	5V/2.5V/2.048V/1.25V, 5ppm/ $^{\circ}$ C, 2.1ppm Peak-to-Peak Noise, MSOP-8 Package
Amplifiers		
LT6236/LT6237/LT6238	Single/Dual/Quad Operational Amplifier with Low Wideband Noise	215MHz, 3.5mA/Amplifier, 1.1nV/ $\sqrt{\text{Hz}}$
LT6233/LT6234/LT6235	Single/Dual/Quad Low Noise Rail-to-Rail Output Op Amps	60MHz, 1.2mA, 1.2nV/ $\sqrt{\text{Hz}}$, 15V/ μ s, 0.5mV
LTC6252/LTC6253/ LTC6254	720MHz, 3.5mA Power Efficient Rail-to-Rail I/O Op Amp	720MHz GBW, Unity Gain Stable, Low Noise

234516f